

EAO – Your Expert Partner for  
**Human Machine Interfaces**



## EAO Product Information

Series 92



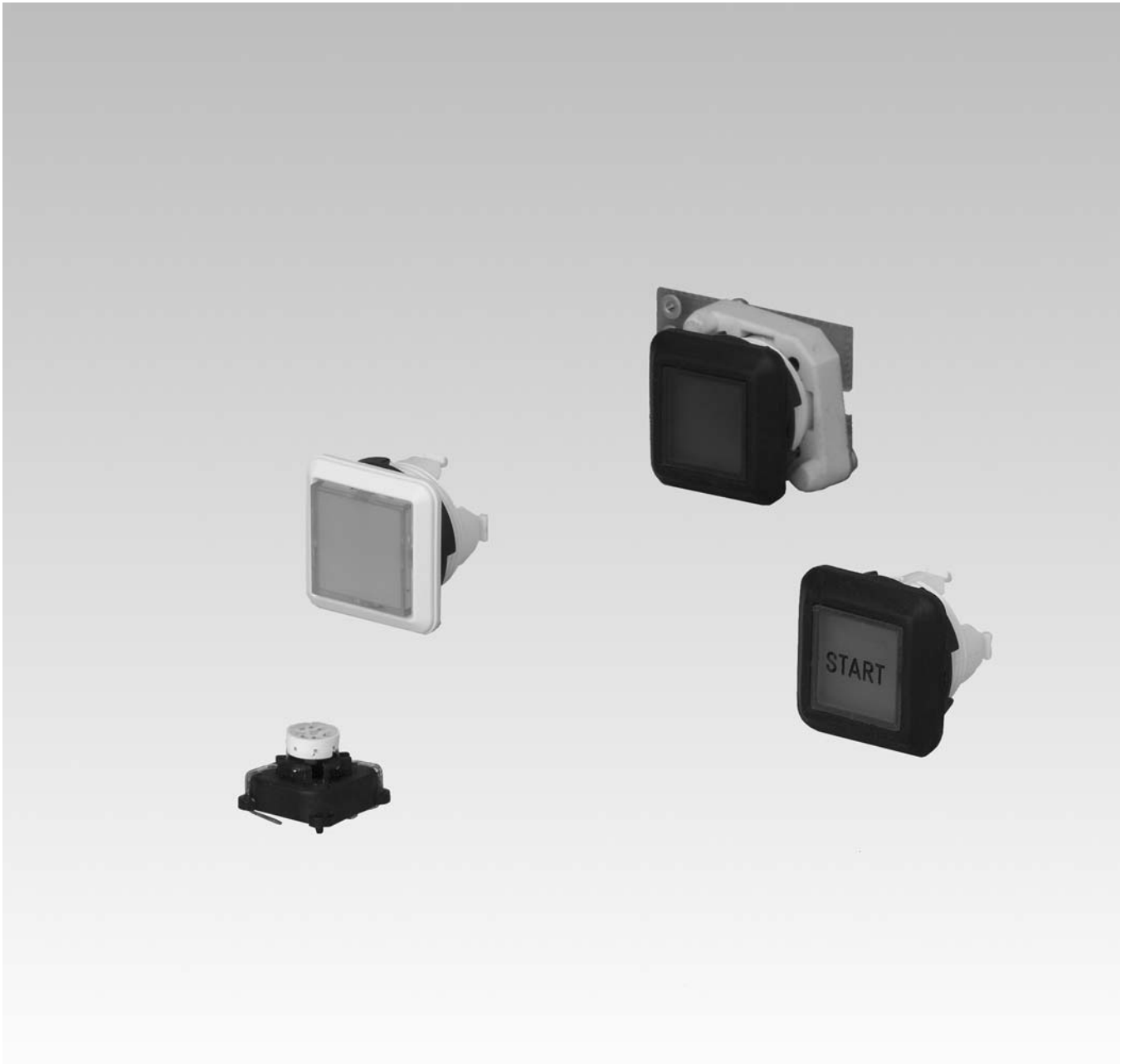

Description .....	3
Product Assembly .....	4
Mounting instruction .....	5
PCB Pushbuttons .....	6
Accessories.....	9
Spare Parts.....	12
Technical Data.....	14
Application guidelines.....	15
Marking .....	16
Drawings.....	17
Index.....	20

## Product Information

### General notes

With the series 92, users have a comprehensive range of applications at their disposal in the PCB key range. In particular, this series is an interesting alternative to the membrane switching system, because it offers convincing advantages, such as: Saving on initial costs, short manufacturing times, all-over illumination and a reliable and nevertheless removable PCB fastening technology.

With the series 92, many different applications are possible even as a discrete switch.

Thanks to front sealing IP 67, and the use of chemical-resistant materials, the elements of this series are suited for industrial use.

The actuator, measuring 18.8 x 18.8 mm at the front (18.8 x 18.4 mm IP 40), is available as an indicator, pushbutton or illuminated pushbutton in marked or unmarked versions.

In order to have matching colours, the actuator element can be supplied with different colours. The switching element complies with international protection level IP 40 and is solder-proof on the connection side. The specially formed connection legs prevent it from falling out when using flow soldering.

### Mounting

The actuators of the series 92 are made for the standard 16 mm dia. mounting hole and fastened tightly to the front panel by means of a fixing nut. Mounting torque max. 50 Ncm.

The switching element is mounted on the printed board independently of the actuator. The arrangement of contacts is based on the matrix dimension 2.54 mm (1/10"). By means of the mounting flange, the PCB can be snapped on the pre-assembled actuator. Later adjustment is no longer necessary. The mounting flange is fastened to the PCB with two 1.8 mm dia. screws, also independent of the actuator. The positioning and the number of flanges is determined by the size of the front panel or PCB.

The actuators are protected against distortion.

### Lenses

The flat front bezel with integrated pressure plate, made of UV resistant TPE has a black finish (standard). Colour variations enable the manufacture of transparent pressure plates of different colours.

### Marking

For further information about hot stamping, laser marking and film inserts see part Marking.

### Illumination

Perfect illumination of the touch surfaces available in various colours is assured by the LEDs Bi-Pin T1 in the colours blue, yellow, green, orange, red and white.

Luminosity and wave length scattering caused by the technology used in the LED manufacturing processes may lead to visual differences in our products.

### Cleaning of soldered PCB

PCBs are often cleaned after machine soldering. When doing this, care must be taken to prevent the "cleaning fluid" polluted with dirt, grease and flux from penetrating the switch.

## Specimen order

### Illuminated pushbutton :

- Illuminated pushbutton actuator, IP 40, fronting black, lens yellow 92-458.400

### Essential accessories :

- Switching element illuminative 92-851.342
- Single-LED T1 Bi-Pin, yellow 10-2602.3174D
- Mounting flange 92-960.0

*We reserve the right to modify technical data  
All dimensions in mm*

## Pushbutton illuminative, IP 40



- 1 Lens
- 2 Actuator housing
- 3 Bezel
- 4 Fixing nut
- 5 Mounting flange
- 6 Switching element
- 7 Fixing screws

## Pushbutton illuminative, IP 67

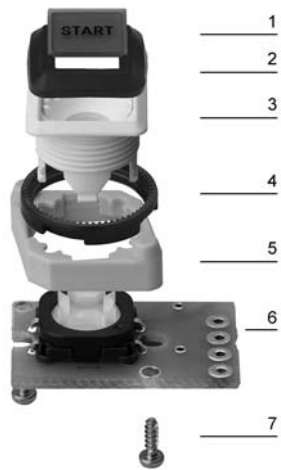

- 1 Lens
- 2 Front bezel
- 3 Actuator housing
- 4 Fixing nut
- 5 Mounting flange
- 6 Switching element
- 7 Fixing screws

## Arrangement mounting flange

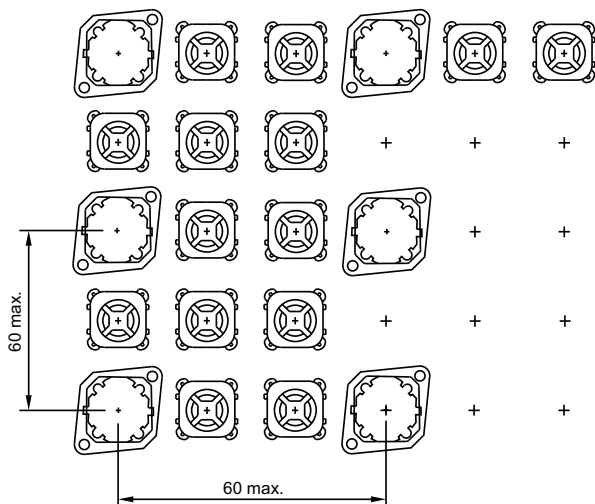

The arrangement of the mounting flanges and their number is determined by the size of the front panel or PCB. To ensure uniform, tactile switching, we recommend a layout of the flanges as per adjacent sketch.

For large PCBs with several switching elements we recommend the following procedure :

1. Fit the actuator to the front panel.
2. Clip the mounting flange to the rear of the intended actuator.
3. Screw the PCB with the components soldered to it to the assembled mounting flange.

This arrangement applies to PCBs 1.6 mm thick.

## Dismantling mounting flange

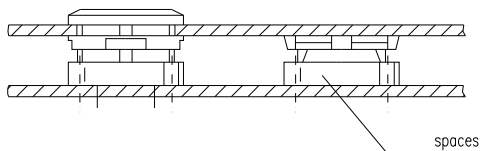

The tool 92-971.0 must be used for removing the mounting flange from the actuator. Before removing the flange, the PCB fixing screws must be loosened.



If the number of actuators is insufficient, use the spacer 92-965.0 which can be attached to the front panel.

The spacer can be adjusted to the following front panel thicknesses: 1.5/2/2.2/3/3.5/4 mm and can be stuck to the back of the panel free of dirt and grease.

## Indicator actuator



### Essential Accessories:

-  Illumination element PCB mounting page 9
-  Mounting flange page 11
-  Single-LED page 10

Indicator actuator	Front protection	Front bezel	Lens	Ø 18.8 x 18.8 mm Typ-Nr.	Ø 18.4 x 18.4 mm Typ-Nr.	Mounting dimensions		Technical drawing	
Indicator actuator	IP 67	Plastic black	Plastic blue transparent	<b>92-143.600</b>		1	3	0.003	
			Plastic colourless transparent	<b>92-143.700</b>		1	3	0.003	
			Plastic green transparent	<b>92-143.500</b>		1	3	0.003	
			Plastic orange transparent	<b>92-143.300</b>		1	3	0.003	
			Plastic red transparent	<b>92-143.200</b>		1	3	0.003	
			Plastic yellow transparent	<b>92-143.400</b>		1	3	0.003	
		Plastic white	Plastic blue transparent	<b>92-043.600</b>		1	3	0.003	
			Plastic colourless transparent	<b>92-043.700</b>		1	3	0.003	
			Plastic green transparent	<b>92-043.500</b>		1	3	0.003	
			Plastic orange transparent	<b>92-043.300</b>		1	3	0.003	
			Plastic red transparent	<b>92-043.200</b>		1	3	0.003	
			Plastic yellow transparent	<b>92-043.400</b>		1	3	0.003	
		IP 40	Plastic black	Plastic blue transparent		<b>92-158.600</b>	1	4	0.003
				Plastic colourless transparent		<b>92-158.700</b>	1	4	0.003
	Plastic green transparent				<b>92-158.500</b>	1	4	0.003	
	Plastic orange transparent				<b>92-158.300</b>	1	4	0.003	
	Plastic red transparent				<b>92-158.200</b>	1	4	0.003	
	Plastic smoked transparent				<b>92-158.100</b>	1	4	0.003	
	Plastic yellow transparent				<b>92-158.400</b>	1	4	0.003	
	Plastic white			Plastic blue transparent		<b>92-058.600</b>	1	4	0.003
Plastic colourless transparent				<b>92-058.700</b>	1	4	0.003		
			Plastic green transparent		<b>92-058.500</b>	1	4	0.003	
		Plastic orange transparent		<b>92-058.300</b>	1	4	0.003		
		Plastic red transparent		<b>92-058.200</b>	1	4	0.003		
		Plastic smoked transparent		<b>92-058.100</b>	1	4	0.003		
		Plastic yellow transparent		<b>92-058.400</b>	1	4	0.003		



Mounting dimensions from page 18, Technical drawing from page 18



## Pushbutton actuator



### Essential Accessories:

-  Mounting flange page 11
-  Switching element PCB mounting illuminative page 9

	Front protection	Front bezel	Lens	Ø 18.8 x 18.8 mm Typ-Nr.	Ø 18.4 x 18.4 mm Typ-Nr.	Mounting dimensions	Technical drawing	Circuit drawing	
<b>Pushbutton actuator</b>	IP 67	Plastic black	Plastic black opaque	<b>92-441.000</b>		1	3	1	0.002
			Plastic grey opaque	<b>92-441.800</b>		1	3	1	0.002
		Plastic white	Plastic black opaque	<b>92-341.000</b>		1	3	1	0.002
			Plastic grey opaque	<b>92-341.800</b>		1	3	1	0.002
	IP 40	Plastic black	Plastic black opaque		<b>92-456.000</b>	1	4	1	0.002
			Plastic grey opaque		<b>92-456.800</b>	1	4	1	0.002
			Plastic white opaque		<b>92-456.900</b>	1	4	1	0.002
		Plastic white	Plastic black opaque		<b>92-356.000</b>	1	4	1	0.002
			Plastic grey opaque		<b>92-356.800</b>	1	4	1	0.002
			Plastic white opaque		<b>92-356.900</b>	1	4	1	0.002

Mounting dimensions from page 18, Technical drawing from page 18, Circuit drawing from page 19

## Illuminated pushbutton actuator



### Essential Accessories:

- Mounting flange page 11
- Single-LED page 10
- Switching element PCB mounting illuminative page 9

	Front protection	Front bezel	Lens	Ø 18.8 x 18.8 mm Typ-Nr.	Ø 18.4 x 18.4 mm Typ-Nr.	Mounting dimensions	Technical drawing	Circuit drawing	EOL
<b>Illuminated pushbutton actuator</b>	IP 67	Plastic black	Plastic blue transparent	<b>92-443.600</b>		1	3	1	0.003
			Plastic colourless transparent	<b>92-443.700</b>		1	3	1	0.003
			Plastic green transparent	<b>92-443.500</b>		1	3	1	0.003
			Plastic orange transparent	<b>92-443.300</b>		1	3	1	0.003
			Plastic red transparent	<b>92-443.200</b>		1	3	1	0.003
			Plastic yellow transparent	<b>92-443.400</b>		1	3	1	0.003
		Plastic white	Plastic blue transparent	<b>92-343.600</b>		1	3	1	0.003
			Plastic colourless transparent	<b>92-343.700</b>		1	3	1	0.003
			Plastic green transparent	<b>92-343.500</b>		1	3	1	0.003
			Plastic orange transparent	<b>92-343.300</b>		1	3	1	0.003
			Plastic red transparent	<b>92-343.200</b>		1	3	1	0.003
			Plastic yellow transparent	<b>92-343.400</b>		1	3	1	0.003
	IP 40	Plastic black	Plastic blue transparent		<b>92-458.600</b>	1	4	1	0.003
			Plastic colourless transparent		<b>92-458.700</b>	1	4	1	0.003
			Plastic green transparent		<b>92-458.500</b>	1	4	1	0.003
			Plastic orange transparent		<b>92-458.300</b>	1	4	1	0.003
			Plastic red transparent		<b>92-458.200</b>	1	4	1	0.003
			Plastic smoked transparent		<b>92-458.100</b>	1	4	1	0.003
		Plastic white	Plastic blue transparent		<b>92-358.600</b>	1	4	1	0.003
			Plastic colourless transparent		<b>92-358.700</b>	1	4	1	0.003
			Plastic green transparent		<b>92-358.500</b>	1	4	1	0.003
			Plastic orange transparent		<b>92-358.300</b>	1	4	1	0.003
			Plastic red transparent		<b>92-358.200</b>	1	4	1	0.003
			Plastic smoked transparent		<b>92-358.100</b>	1	4	1	0.003
		Plastic yellow transparent		<b>92-358.400</b>	1	4	1	0.003	

Mounting dimensions from page 18, Technical drawing from page 18, Circuit drawing from page 19

## Front

### Blind plug

		Ø 18 x 18 mm Typ-Nr.	Mounting dimensions	
<b>Blind plug</b>	Plastic black	<b>51-948.0</b>	1	0.003



Mounting dimensions from page 18

## Backside

### Illumination element PCB mounting

The customer has to decide what series resistor shall be used to the LED

	Terminals	Typ-Nr.	Component layout Technical drawing	
<b>Illumination element PCB mounting</b>	P	<b>92-800.042</b>	1	1



Illumination and mounting flange to be ordered separately.

Terminals: P = PCB terminal

Component layout from page 17, Technical drawing from page 18

### Switching element PCB mounting illuminative

The customer has to decide what series resistor shall be used to the LED

	Terminals	Typ-Nr.	Component layout Technical drawing Circuit drawing	
<b>Switching element PCB mounting illuminative</b>	P	<b>92-851.342</b>	2	5



Illumination and mounting flange to be ordered separately.

Terminals: P = PCB terminal

Component layout from page 17, Technical drawing from page 18, Circuit drawing from page 19

## Spacer

	Typ-Nr.	
<b>Spacer</b>	<b>92-965.0</b>	0.003



When fitting, ensure that back of panel is free of grease and dirt

## PCB assembled

	Typ-Nr.	
<b>PCB assembled</b> for discrete switching applications including switching element and mounting flange, soldering terminal (assembled PCB incl. series resistor and LED on request)	<b>92-981.0</b>	0.003



## Illumination

### Single-LED

The customer has to decide what series resistor shall be used to the LED

	Socket	Operating voltage/-current	Light colour	Typ-Nr.	
<b>Single-LED</b>	T1 Bi-Pin	2.1 VDC, 20 mA	orange	<b>10-2602.3203L</b>	0.001
			red	<b>10-2602.3202L</b>	0.001
		2.2 VDC, 20 mA	yellow	<b>10-2602.3174D</b>	0.001
			blue	<b>10-2602.3206L</b>	0.001
			green	<b>10-2602.3205L</b>	0.001
			white	<b>10-2602.3209L</b>	0.001
3.5 VDC, 20 mA	blue	<b>10-2602.3206L</b>	0.001		
	green	<b>10-2602.3205L</b>	0.001		



### Bi-colour LED

The customer has to decide what series resistor shall be used to the LED

	Socket	Light colour	Operating voltage/-current	Typ-Nr.	
<b>Bi-colour LED</b>	T1 Bi-Pin	red/green	1.9/3.5 VDC, 20 mA	<b>10-2603.320AL</b>	0.001
		yellow/green	2.0/3.2 VDC, 20 mA	<b>10-2603.320CL</b>	0.001



### Multi-LED

The customer has to decide what series resistor shall be used to the LED

	Socket	Operating voltage/-current	Light colour	Typ-Nr.	
<b>Multi-LED</b>	T1 Bi-Pin	12 VDC, 40 mA	yellow	<b>10-5609.3174D</b>	0.001



## Assembling

### Anti-twist ring

for front panel thickness max. 2 mm

	Typ-Nr.	
<b>Anti-twist ring</b> Mounting hole size 16 mm dia.	<b>51-910</b>	0.001



## Mounting flange

	Typ-Nr.	Technical drawing	
<b>Mounting flange</b>	<b>92-960.0</b>	2	0.001



Technical drawing from page 18

## Lens remover

	Typ-Nr.	
<b>Lens remover</b> for lens plate IP 40 only	<b>18-910</b>	0.002



## Mounting tool

	Typ-Nr.	
<b>Mounting tool</b> for Indicator 16 mm dia.	<b>01-907</b>	0.020



## Dismantling tool

	Typ-Nr.	
<b>Dismantling tool</b> for actuator dismantling of switching- and illumination element and mounting flange	<b>92-971.0</b>	0.002



**Pushbutton- and Illuminated pushbutton actuator IP 40****Pushbutton- and Illuminated pushbutton actuator IP 40**

Lens and Front bezel order separately

	Front ring	∅ 18.4 x 18.4 mm Typ-Nr.	
<b>Pushbutton- and Illuminated pushbutton actuator IP 40</b>	Plastic black	<b>92-450.000</b>	0.003
	Plastic white	<b>92-350.000</b>	0.003

**Lens for pushbuttons and indicators IP 40**

	Lens	∅ 18.4 x 18.4 mm Typ-Nr.	
<b>Lens for pushbuttons and indicators IP 40</b> 13.2 x 13.2 mm with white Marking plate	Plastic black opaque	<b>92-956.000</b>	0.001
	Plastic blue translucent	<b>92-956.600</b>	0.001
	Plastic blue transparent	<b>92-958.600</b>	0.001
	Plastic colourless transparent	<b>92-958.700</b>	0.001
	Plastic green translucent	<b>92-956.500</b>	0.001
	Plastic green transparent	<b>92-958.500</b>	0.001
	Plastic grey opaque	<b>92-956.800</b>	0.001
	Plastic orange translucent	<b>92-956.300</b>	0.001
	Plastic orange transparent	<b>92-958.300</b>	0.001
	Plastic red translucent	<b>92-956.200</b>	0.001
	Plastic red transparent	<b>92-958.200</b>	0.001
	Plastic smoked transparent	<b>92-958.100</b>	0.001
	Plastic white opaque	<b>92-956.900</b>	0.001
	Plastic yellow translucent	<b>92-956.400</b>	0.001
Plastic yellow transparent	<b>92-958.400</b>	0.001	

**Front bezel for pushbuttons and indicators IP 40**

	Front ring	∅ 18.4 x 18.4 mm Typ-Nr.	
<b>Front bezel for pushbuttons and indicators IP 40</b>	Plastic black	<b>92-912.0</b>	0.001
	Plastic white	<b>92-912.9</b>	0.001

**Pushbutton- and Illuminated pushbutton actuator IP 67****Pushbutton- and Illuminated pushbutton actuator IP 67**

Lens order separately

	Front ring	∅ 18.8 x 18.8 mm Typ-Nr.	
<b>Pushbutton- and Illuminated pushbutton actuator IP 67</b>	Plastic black	<b>92-440.000</b>	0.003
		<b>92-340.000</b>	0.003



## Indicator actuator IP 67

Lens plate order separately

	Front ring	∅ 18.8 x 18.8 mm Typ-Nr.	
<b>Indicator actuator IP 67</b>	Plastic black	<b>92-140.000</b>	0.003



## Lens for pushbuttons and indicators IP 67

	Lens plate	∅ 18.8 x 18.8 mm Typ-Nr.	
<b>Lens for pushbuttons and indicators IP 67</b> 12 x 12 mm	Plastic black flush opaque	<b>92-941.000</b>	0.001
	Plastic blue flush transparent	<b>92-941.600</b>	0.001
	Plastic colourless flush transparent	<b>92-941.700</b>	0.001
	Plastic green flush transparent	<b>92-941.500</b>	0.001
	Plastic grey flush opaque	<b>92-941.800</b>	0.001
	Plastic orange flush transparent	<b>92-941.300</b>	0.001
	Plastic red flush transparent	<b>92-941.200</b>	0.001
	Plastic yellow flush transparent	<b>92-941.400</b>	0.001



## Pushbutton- and Illuminated pushbutton

### Switching system

Short-travel switching system with 2 independent contact points and tactile operation.  
Guarantees reliable switching even of very light loads.  
Fitted with 1 normally open contact.

### Material

#### Lens

Polycarbonate (PC)

#### Front bezel

Thermoplastic Elastomer (TPE)

#### Frame

Thermoplastic Polyester (PBT)

#### Material of contact

Gold (Au)

#### Switching element

Thermoplastic Polyester (PET, PBT) and Polyacetale (POM)

#### Actuator housing

Thermoplastic Polyester (PBT)

### Mechanical characteristics

#### Tightening torque

Fixing screw 40 Ncm recommended  
Fixing nut max. 50 Ncm

#### Actuating force

2.7 N  $\pm$  1 N measured at the switching element  
5 N measured at the lens

#### Actuating travel

Switching element 0.4 mm

#### Rebound time

$\leq$  1 ms

#### Resistance to heat of soldering

260 °C, 5 s, as per IEC 60068-2-20

#### Mechanical lifetime

$\geq$  1 Million operations as per IEC 60512-5-9a

### Electrical characteristics

#### Contact resistance

Starting value (initial)  $\leq$  100 m $\Omega$  as per IEC 60512-2-2b

#### Isolation resistance

$\geq$  10<sup>9</sup>  $\Omega$  between all terminals at 100 VDC, as per IEC 60512-2-3a

#### Electrical life

$\geq$  500 000 operations at 42 VDC, 50 mA as per IEC 60512-5-9c.  
When attention is paid to the direction of current flow from terminal 3/4 to 1/2 the electrical life can be prolonged.

#### Electrostatic discharge (ESD)

15 kV

### Switch rating

Switching voltage	min. 50 mV AC/DC max. 42 V AC/DC
Switching current	min. 10 $\mu$ A AC/DC max. 100 mA AC/DC
Power rating	max. 2 W

### Electric strength

500 VAC, 50 Hz, 1 min, as per IEC 60512-2-4a

### Environmental conditions

#### Storage temperature

-40 °C ... +80 °C

#### Operating temperature

-25 °C ... +70 °C

#### Front protection

Switching element IP 40 (fluxproof to DIN 41640 Part 84)  
front IP 67 or IP 40

#### Shock resistance

$\leq$  50 g for 11 ms as per IEC 60512-4-6c

#### Vibration resistance

(sinusoidal)  
10 g at 10-2000 Hz, amplitude 0.75 mm as per IEC 60512-4-6d

### Approvals

#### Declaration of conformity

RoHS



## Suppressor circuits

When switching inductive loads such as relays, DC motors, and DC solenoids, it is always important to absorb surges (e.g. with a diode) to protect the contacts. When these inductive loads are switched off, a counter emf can severely damage switch contacts and greatly shorten lifetime.

Fig. 1 shows an inductive load with a free-wheeling diode connected in parallel. This free-wheeling diode provides a path for the inductor current to flow when the current is interrupted by the switch. Without this free-wheeling diode, the voltage across the coil will be limited only by dielectric breakdown voltages of the circuit or parasitic elements of the coil. This voltage can be kilovolts in amplitude even when nominal circuit voltages are low (e.g. 12 VDC) see Fig. 2.

The free-wheeling diode should be chosen so that the reverse breakdown voltage is greater than the voltage driving the inductive load. The DC blocking voltage (VR) of the free-wheeling diode can be found in the datasheet of a diode. The forward current should be equal or greater than the maximum current flowing through the load.

**To get an efficient protection, the free-wheeling diode must be connected as close as possible to the inductive load!**

Switching with inductive load  
Fig. 1



Counter emf  
over load without free-wheeling diode  
Fig. 2



## General notes

If desired, the actuators of the series 92 can be supplied ready marked. With your order please enclose a list of the desired markings or a drawing, showing the type or size of script or the symbols desired.

### 1. Laser engraving (Fig. 1)

In addition to the most commonly used world languages, in DIN 1451-3 close spacing, other typefaces are available as Scandinavian, Slavic, Greek, Russian and Polish.

Red, blue and black lenses are filled with white colour. Other colour lenses are filled in black. Standard height of letters is 2 mm. If the height is not specified, we will supply 2 mm engraved letters.

### 2. Hot stamping (Fig. 1)

For larger series it is worth considering markings by means of hot stamping. We will be pleased to advise you.

For letters and figures, typefaces with 2.5 mm, 3 mm and 4 mm are available.

### 3. Film inserts (Fig. 2)

Instead of using engraving, the actuator can be fitted with transparent film inserts.

However, for this purpose the use of transparent lens caps is recommended. If smoked lens caps are used the lettering does not become visible until the LED is alight.

Max. size of film insert  
11.4 x 11.4 mm for IP 40  
10.4 x 10.4 mm for IP 67  
Film thickness 0.2 mm.

All dimensions in mm

Height of letters h	Number of lines	Number of (target value) capital letters per line	Number of (target value) small letters per line
3	2	5 - 6	6
4	2	4	4
5	1	3	3 - 4
6	1	2 - 3	3
8	1	2	2

Fig. 1

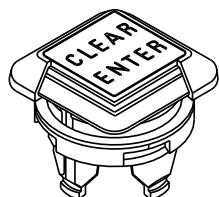
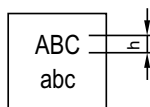
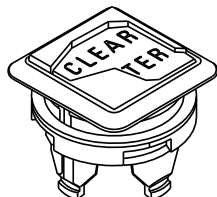

Fig. 2



## Component layout

### 1 Illumination element PCB mounting page 9

Single-LED

Bi-colour-LED

Drilling plan (Elementside)

Drilling plan (Elementside)

- A Fixing holes for mounting flange (92-960.0)
- B Holes for LED
- C Holes for centering pins

- A Fixing holes for mounting flange (92-960.0)
- B Holes for Bi-colour LED:  
BA1 (green) + BA2 (yellow or red) = Anodes, BC = Cathode
- C Holes for centering pins

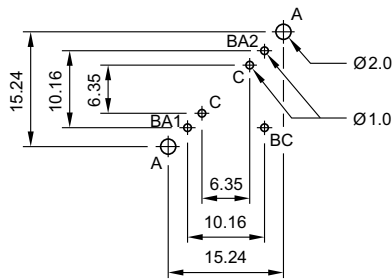
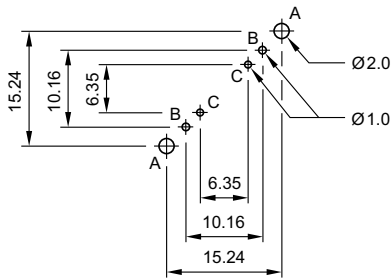

Libraries for the PCB layout-system p-cad 200X see : [www.pcad.com/en/library](http://www.pcad.com/en/library) Third-party Libraries

### 2 Switching element PCB mounting illuminative page 9

Single-LED

Bi-colour-LED

Drilling plan (Elementside)

Drilling plan (Elementside)

- A Fixing holes for mounting flange (92-960.0)
- B Holes for LED
- C Holes for contact pins  
Pad max. Ø 2.5 mm  
Through-connection recommended

- A Fixing holes for mounting flange (92-960.0)
- B Holes for Bi-colour LED:  
BA1 (green) + BA2 (yellow or red) = Anodes, BK = Cathode
- C Holes for contact pins  
Pad max. Ø 2.5 mm  
Through-connection recommended

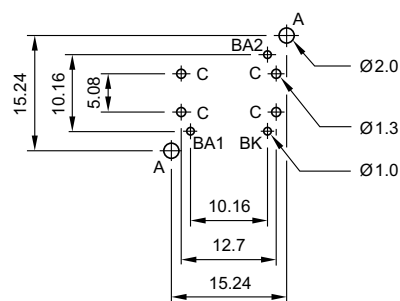
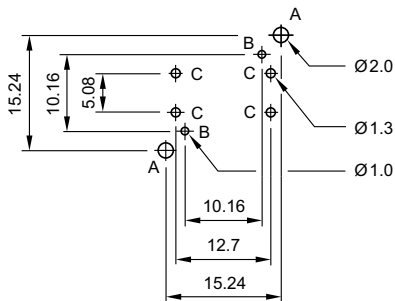

Libraries for the PCB layout-system p-cad 200X see : [www.pcad.com/en/library](http://www.pcad.com/en/library) Third-party Libraries

## Mounting dimensions

1 Indicator actuator page 6 | Pushbutton actuator page 7 | Illuminated pushbutton actuator page 8 | Blind plug page 9

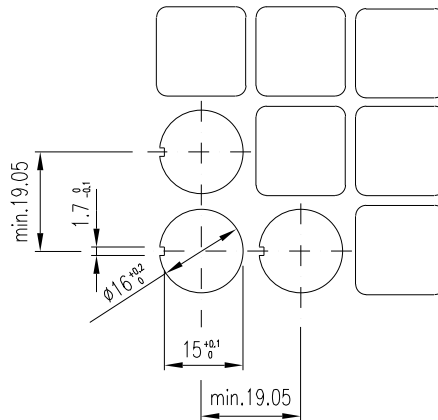
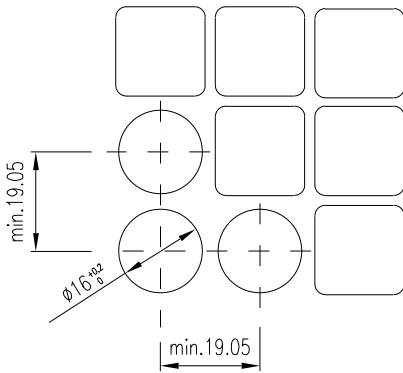

## Technical drawing

1 Illumination element PCB mounting page 9

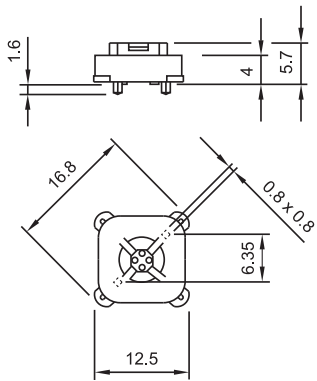

2 Mounting flange page 11

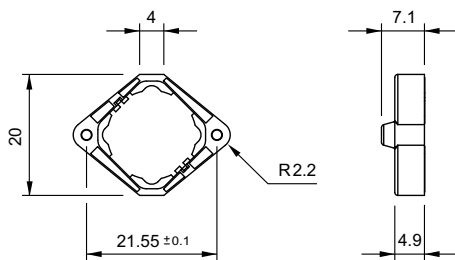

3 Indicator actuator page 6 | Pushbutton actuator page 7 | Illuminated pushbutton actuator page 8

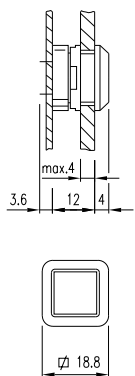

4 Indicator actuator page 6 | Pushbutton actuator page 7 | Illuminated pushbutton actuator page 8

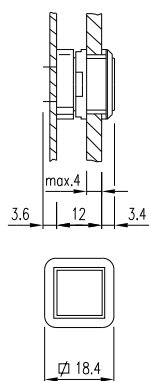

5 Switching element PCB mounting illuminative page 9

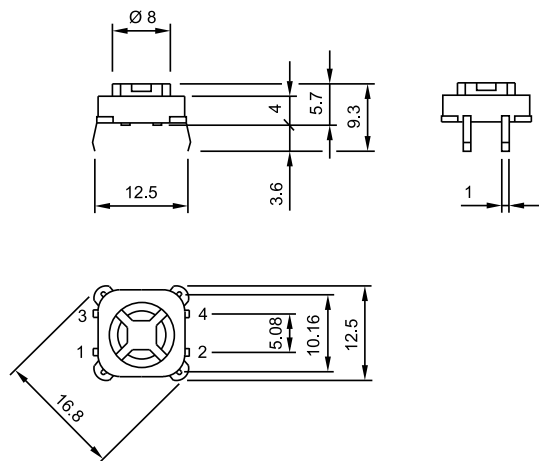

## Circuit drawing

1 Pushbutton actuator page 7 | Illuminated pushbutton actuator page 8



2 Switching element PCB mounting illuminative page 9

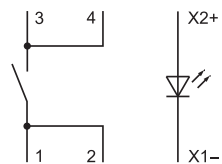

# Index from Typ-Nr.

Typ-Nr.	Page	Typ-Nr.	Page	Typ-Nr.	Page
01-907	11	92-443.200	8		
10-2602.3174D	10	92-443.300	8		
10-2602.3202L	10	92-443.400	8		
10-2602.3203L	10	92-443.500	8		
10-2602.3205L	10	92-443.600	8		
10-2602.3206L	10	92-443.700	8		
10-2602.3209L	10	92-450.000	12		
10-2603.320AL	10	92-456.000	7		
10-2603.320CL	10	92-456.800	7		
10-5609.3174D	10	92-456.900	7		
18-910	11	92-458.100	8		
51-910	10	92-458.200	8		
51-948.0	9	92-458.300	8		
92-043.200	6	92-458.400	8		
92-043.300	6	92-458.500	8		
92-043.400	6	92-458.600	8		
92-043.500	6	92-458.700	8		
92-043.600	6	92-800.042	9		
92-043.700	6	92-851.342	9		
92-058.100	6	92-912.0	12		
92-058.200	6	92-912.9	12		
92-058.300	6	92-941.000	13		
92-058.400	6	92-941.200	13		
92-058.500	6	92-941.300	13		
92-058.600	6	92-941.400	13		
92-058.700	6	92-941.500	13		
92-140.000	13	92-941.600	13		
92-143.200	6	92-941.700	13		
92-143.300	6	92-941.800	13		
92-143.400	6	92-956.000	12		
92-143.500	6	92-956.200	12		
92-143.600	6	92-956.300	12		
92-143.700	6	92-956.400	12		
92-158.100	6	92-956.500	12		
92-158.200	6	92-956.600	12		
92-158.300	6	92-956.800	12		
92-158.400	6	92-956.900	12		
92-158.500	6	92-958.100	12		
92-158.600	6	92-958.200	12		
92-158.700	6	92-958.300	12		
92-340.000	12	92-958.400	12		
92-341.000	7	92-958.500	12		
92-341.800	7	92-958.600	12		
92-343.200	8	92-958.700	12		
92-343.300	8	92-960.0	11		
92-343.400	8	92-965.0	9		
92-343.500	8	92-971.0	11		
92-343.600	8	92-981.0	10		
92-343.700	8				
92-350.000	12				
92-356.000	7				
92-356.800	7				
92-356.900	7				
92-358.100	8				
92-358.200	8				
92-358.300	8				
92-358.400	8				
92-358.500	8				
92-358.600	8				
92-358.700	8				
92-440.000	12				
92-441.000	7				
92-441.800	7				



	<b>EAO AG</b>
	Tannwaldstrasse 88 4601 Olten, Switzerland
<b>E-mail</b>	info@eao.com
<b>Website</b>	www.eao.com
	<b>Austria</b>
Phone	+49 201 85 87 0
Fax	+49 201 85 87 210
E-mail	sales.ede@eao.com
	<b>Belgium</b>
Phone	+32 3 777 82 36
Fax	+32 3 777 84 19
E-mail	sales.ebl@eao.com
	<b>China</b>
Phone	+852 27 86 91 41
Fax	+852 27 86 95 61
E-mail	sales.ehk@eao.com
	<b>France</b>
Phone	+33 1 64 43 37 37
Fax	+33 1 64 43 37 49
E-mail	sales.esa@eao.com
	<b>Germany</b>
Phone	+49 201 85 87 0
Fax	+49 201 85 87 210
E-mail	sales.ede@eao.com
	<b>Italy</b>
Phone	+39 035 481 0189
Fax	+39 035 481 3786
E-mail	sales.eit@eao.com
	<b>Japan</b>
Phone	+81 3 5444 5411
Fax	+81 3 5444 0345
E-mail	sales.esj@eao.com
	<b>Netherlands</b>
Phone	+31 78 653 17 00
Fax	+31 78 653 17 99
E-mail	sales.enl@eao.com
	<b>Sweden</b>
Phone	+46 8 683 86 60
Fax	+46 8 724 29 12
E-mail	sales.esw@eao.com
	<b>Switzerland</b>
Phone	+41 62 388 95 00
Fax	+41 62 388 95 55
E-mail	sales.ech@eao.com
	<b>United Kingdom</b>
Phone	+44 1444 236 000
Fax	+44 1444 236 641
E-mail	sales.euk@eao.com
	<b>USA</b>
Phone	+1 203 877 4577
Fax	+1 203 877 3694
E-mail	sales.eus@eao.com
	<b>Other Countries</b>
Phone	+41 62 286 92 10
Fax	+41 62 296 21 62
E-mail	info@eao.com