

Absolute Singleturn Serie ENCAN 36 M, CANopen

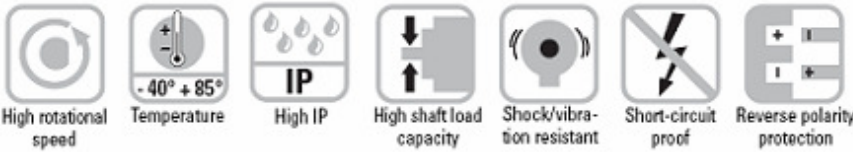

Rugged

- Ensures long service life and reliability of the application, no wear
Non-contact measuring system
- Stays sealed even when subjected to harsh everyday use. Offers security against failures in the field
Solid die-cast housing with up to IP 69K protection
- Can be used for a wide temperature range without additional expense.
Wide temperature range (-40 °C ... +85 °C)
- Increased ability to withstand vibration and installation errors. Eliminates machine downtime and repairs.
High shock resistance (> 500g) and vibration resistance (>30g)
- Can be used in outdoor applications with large fluctuations in temperature.
Resistant against humidity and condensation.



Compact

- Can be used where space is tight
Overall diameter of only 36 mm
- Compact encoder, suitable for large shafts
Blind hollow shaft up to 10 mm,

Versatile

- Latest field bus performance for the applications
CANopen, with the latest profiles
- The suitable connection variant for every specific case
M12 connector or cable connection or fixed connection with M12, connector,
- Position, Speed, working area - The user decides which information is to be available in real-time
Variable PDO mapping in the memory
- Quick and error-free start-up, without setting any switches
Node address, baud rate and termination can be programmed via the bus
- Fast, error-free start-up, no need to set switches
LSS services for configuration of the node address and baud rate via CIA DS 305 V2.0
Node address, baud rate and termination can be programmed via the bus

Mechanical characteristics:

Max. speed:	6000 min ⁻¹
Starting torque	< 0,06 Nm
Weight:	approx. 0,2 kg
Protection acc. to EN 60 529:	IP 67 (IP 69k on request)
Working temperature:	-40 °C ... +85 °C
Materials:	Shaft: stainless steel, Flange: aluminium, Housing: die cast zinc, Cable: PUR
Shock resistance acc. to DIN-IEC 68-2-27:	5000 m/s ² , 6 ms
Vibration resistance acc. to DIN-IEC 68-2-6:	300 m/s ² , 10 ... 2000 Hz
Permanent shock resistance acc. to DIN-IEC 68-2-29	1000 m/s ² , 2 ms
Vibration (broad-band random) to DIN-IEC 68-2-64	5 ... 2500 Hz, 100 m/s ² - rms

All-round protection

IP69k protection on the flange side, robust bearing assemblies with interlocking bearings, mechanically protected shaft seal

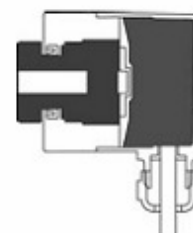

Fully encapsulated electronics, separate mechanical bearing assembly

Absolute Singleturn Serie ENCAN 36 M, CANopen

General electrical characteristics:

Supply voltage:	8 ... 30 V DC
Current consumption (w/o output load):	24 V DC, max. 25 mA
Reverse polarity protection at power supply (U _b):	Yes
Conforms to CE requirements acc. to EN 61000-6-1, EN 61000-6-4 and EN 61000-6-3	
Measurement range:	360°
Linearity:	< 1°
Repeat accuracy:	< 0.1°
Data refresh:	400 µs

Diagnostic LED (two-colour, red/green)

LED ON or blinking red:	Error display
LED ON or blinking green:	Status display

General information about CANopen

The CANopen encoders of the 3658 series support the latest CANopen communication profile according to DS 301 V4.02 . In addition, device-specific profiles like the encoder profile DS 406 V3.1 are available.

The following operating modes may be selected: Polled Mode, Cyclic Mode, Sync Mode. Moreover, scale factors, preset values, limit switch values and many other additional parameters can be programmed via the CAN-Bus. When switching the device on, all parameters, which have been saved on a flash memory to protect them against power failure, are loaded again.

The following output values may be combined in a freely variable way as PDO (PDO mapping): position, as well as the status of the working area.

The encoders are available with a connector or a cable connection. The device address and baud rate can be set/modified by means of the software. The two-colour LED located on the back indicates the operating or fault status of the CAN bus, as well as the status of the internal diagnostics. Node address, baud rate and CANbus termination are programmable

CANopen Communication Profile DS301 V4.02

Among others, the following functionality is integrated:

Class C2 functionality

- NMT Slave
- Heartbeat Protocol
- Identity Object
- Error Behaviour Object
- Variable PDO Mapping self-start programmable (Power on to operational), 3 Sending PDO's
- Node address, baud rate and CANbus
- Programmable termination

Interface characteristics CANopen:

Resolution:	1 ... 16384 (14 bit), (scaleable: 1 ... 16384)
Default value:	16384 (14 bit)
Code:	Binary
Interface:	CAN High-Speed according to ISO 11898, Basic- and Full CAN CAN Specification 2.0 B
Protocol:	CANopen profile DS 406 V3.1 with manufacturer-specific add-ons LSS-Services DS305 V2.0
Baud rate:	10 ... 1000 kbit/s (set by DIP switches/software configurable)
Node address:	1 ... 127 (set by rotary switches / software configurable)
Termination switchable:	Set by DIP switches (software configurable)
LSS Services:	CIA LSS protocol DS305 Global command support for node address and baud rate Selective commands via attributes of the identity object

CANopen Encoder Profile DS406 V3.1

The following parameters can be programmed:

- Event mode
- 1 work area with upper and lower limit and the corresponding output states
- Variable PDO mapping for position, speed, work area status
- Extended failure management for position sensing with integrated temperature control
- User interface with visual display of bus and failure status
1 LED two colours
- Customer-specific memory - 16 Bytes

“Watchdog-controlled” device

LSS Layer Setting Services DS305 V2.0

- Global support of Node-ID and baud rate
- Selective protocol over identity object (1018h)



Absolute Singleturn Serie ENCAN 36 M, CANopen

Dimensions

ø 36 mm, Flange with long torque stop

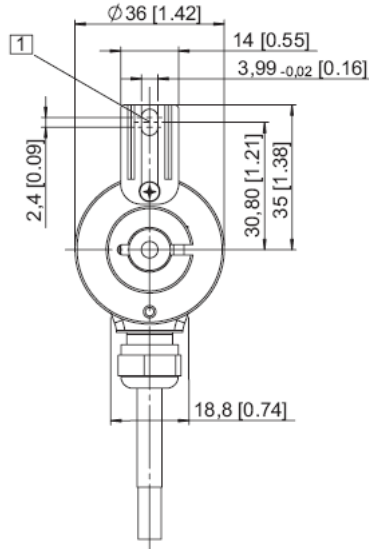
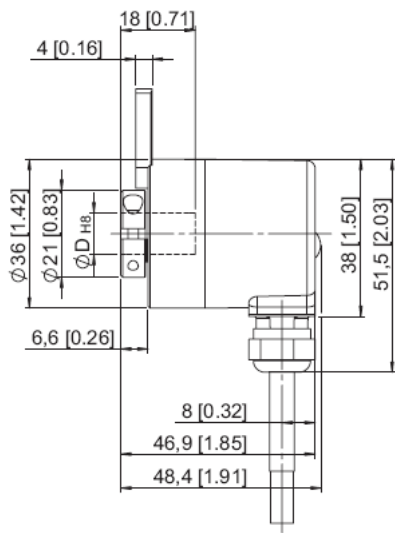

1 Torque stop slot,
 Recommendation: cyl. pin. acc. DIN 7 Ø4

ø 36 mm, Synchro flange

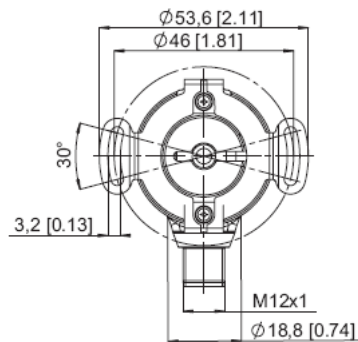
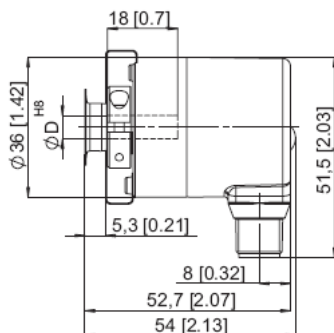
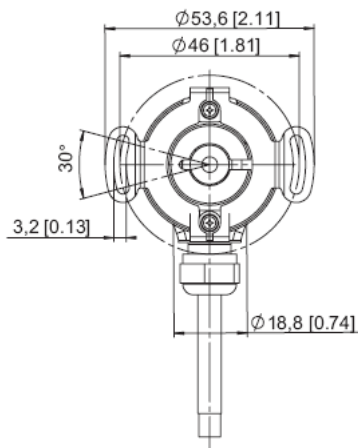
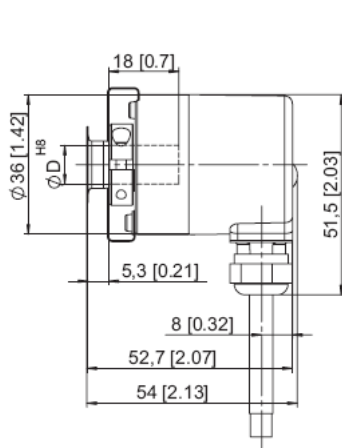

Absolute Singleturn Serie ENCAN 36 M, CANopen

Terminal assignment:

Signal:	+Ub	0 V	CAN GND	CAN High	CAN Low
Pin:	2	3	1	4	5
Col.:	BN	WH	GY	GN	YE

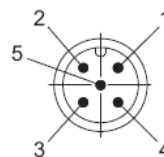

Order code:

ENCAN36M.XXX.X.21XX

