

Multiturn ENFC 90 CANopen/DeviceNet



Your benefit

- Only 60 mm clearance needed
- Patented integrative technology
- Very easy mounting of the hollow shaft version. The encoder is mounted directly on the drive shaft without coupling. This saves up to 30 % cost and 50 % clearance compared to shaft versions.
- Divisions: up to 8192 (13 bits) per revolution, 4096 (12 bits) revolutions
- Contactless multiturn gear with new Intelligent-Sensing-Technology (IST)

- Simply connection patent pending connecting system with removable socket box
- Protection: IP 65

Product features

- CANopen according to profile DSP 406 with additional features
- DeviceNet 2.0 protocol
- Divisions: up to 8192 bits per revolution, up to 4096 revolutions (13x12 bit)
- IP 65
- Extensive M12 accessories program
- available as explosion proof zone 2 and 22

Mechanical characteristics:

Speed: ¹⁾	max. 6000 min ⁻¹
Rotor moment of inertia:	approx. 72 x 10 ⁻⁶ kgm ²
Starting torque shaft hollow shaft version :	< 0.2 Nm
Starting torque shaft shaft version :	< 0.05 Nm
Load capacity of shaft (using solid shaft) ²⁾	radial: 80 N, axial 40 N
Weight:	approx. 0.9 kg
Protection acc. to EN 60 529:	IP 65
Working temperature:	-10° C ... +70 °C ³⁾
Operating temperature:	-20° C ... +80 °C ³⁾
Shaft:	stainless steel, hollow shaft H7
Shock resistance acc. to DIN-IEC 68-2-27:	2500 m/s ² , 6 ms
Vibration resistance acc. to DIN-IEC 68-2-6:	100 m/s ² , 10 ... 2000 Hz

¹⁾ For continuous operation 3000 min⁻¹

²⁾ Shaft version only (at shaft end)

³⁾ Non-condensing

Electrical characteristics:

Supply voltage (U _B):	10 ... 30 V DC
Current consumption:	max. 0.29 A
recommended fuse:	T 0,315 A
Linearity:	± 1/2 LSB (±1 LSB at Resolution 13, 14, 25 Bit)
Codeart:	Binary
Interface:	CAN HIGH-Speed to ISO/DIS 11898, Basic and Full-CAN; CAN-specification 2.0 B (11 and 29 Bit Identifier)
Protocol:	CANopen to Profile DSP 406 DeviceNet Profile for Encoder Release V 2.0
Rate:	programmable via DIP switches 10 ... 1000 Kbits/s
Basic identifier/node:	programmable via DIP switches
Conforms to CE requirements acc. to EN 61000-6-1, EN 61000-6-4 and EN 61000-6-3	
Performance against magnetic influence acc. to EN61000-4, 5	

CANopen
DeviceNet.

Multiturn ENFC 90 CANopen/DeviceNet

CANopen - Device Profile:

General description

The CANopen Device Profiles describe the functionality of the communication and of that part of the CANopen fieldbus system specific to the manufacturer. Device Profile 406 applies to encoders and defines the individual objects independently of the manufacturer. In addition the profile makes provision for additional extended functions specific to the manufacturer; using devices that interface with CANopen offers the advantage of acquiring systems today that are prepared for the needs of the future.

The following functionality is integrated:

- Class C2 functionality
- NMT Slave
- Diagnostics (internal) 2 Bit
- CAN-LED for Bus status
- CAN-LED for operating mode

The following parameters can be programmed:

- Polling mode or auto mode with adjustable time
- Direction
- Number of pulses/rotation 1 ... 8192
- Number of revolutions 1 ... 4096
- Total resolution
- Preset
- Offset

DeviceNet Encoder Profile:

General description:

The DeviceNet Device Profile describes the functionality of the communication and of that part of the DeviceNet fieldbus system specific to the manufacturer. The Encoder Profile applies to encoders and defines the individual objects independently of the manufacturer. In addition the profile makes provision for additional extended functions specific to the manufacturer.

The following functionality is integrated:

- Galvanic isolation of the Fieldbus-stage with DC/DC converter
- Addressing via DIP switches or software
- Diagnostic LED for network and mode
- Baud rate 125, 250 and 500 kbit/s programmable via DIP switches
- Node address 0 ... 63 and baud rate programmable via DIP switches
- Polled mode
- Cyclic mode
- Change of state mode (COS)
- Combination of Polled mode and Cyclic mode
- Combination of Polled mode and COS mode
- Offline connection set
- Device heartbeat
- "Out of box" Configuration
- MAC-ID and Baud rate preset value
MAC-ID = 63

- Baud rate = 125 kBits/s
- 2 I/O Assembly
Position value
Position value and status

The following parameters can be programmed:

- Direction of rotation
- Scaling factor
 - Number of pulses/rotation
 - Total resolution
- Number of revolutions
- Preset value
- Diagnostics mode
- Resolution

Fieldbus encoders can be used in following applications:

CANopen:

Elevators, construction and mobile plant, cranes, agricultural vehicles, special-purposes vehicles.

DeviceNet:

especially suitable for applications in the USA.

Absolute Multiturn Encoder with CANopen/DeviceNet-interface Absolute Multiturn Drehgeber mit CANopen/DeviceNet-Anschluss

Multiturn ENFC 90 CANopen/DeviceNet

Bus in:

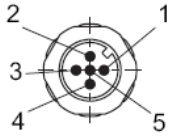

Signal :	DRAIN	+ V DC	- V DC	CAN_H	CAN_L
Pin:	1	2	3	4	5
	GY	RD	BK	WH	BU

Bus out:

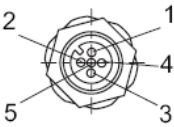

Signal :	DRAIN	+ V DC	- V DC	CAN_H	CAN_L
Pin:	1	2	3	4	5
	GY	RD	BK	WH	BU

Use Couplings for the connection BUS-IN and Connectors for the connection BUS-OUT.
Compatible self-assembly connectors:

Connector (BUS-OUT): 05.B8251-0/9
Coupling (BUS-IN): 05.B8151-0/9
See also Connection Technology section for cable assemblies.

Dimensions:

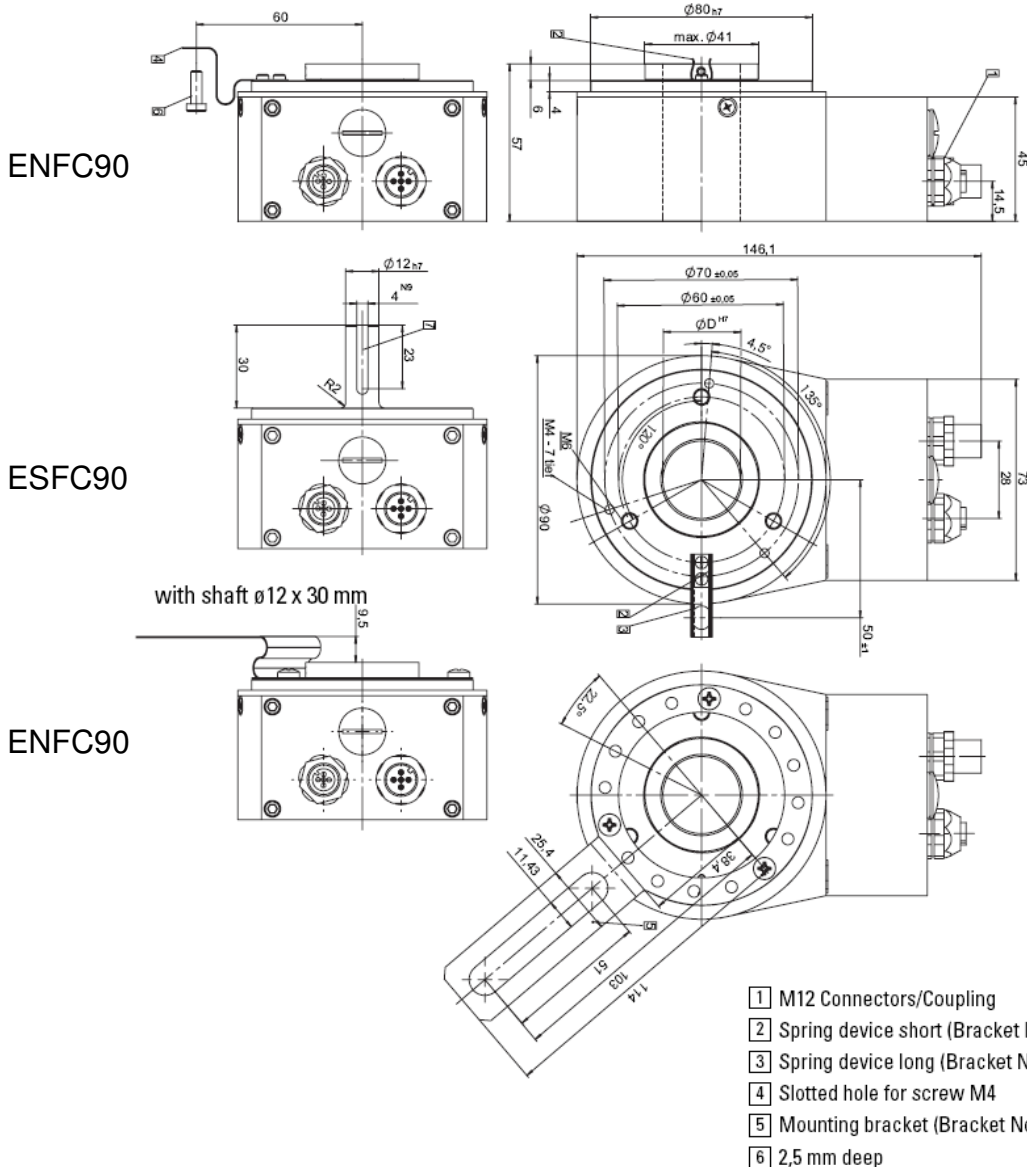

Multiturn ENFC 90 CANopen/DeviceNet

Terminal assignment with terminal box:

Signal :	ENC.		BUS IN			BUS OUT			ENC.		Shield	
	+V DC	GND	GND	CAN_H	CAN_L	CAN_L	CAN_H	GND	GND	+V DC		
Pin:	1	2	3	4	5	6	7	8	9	10	11	12

Dimensions (terminal box version):

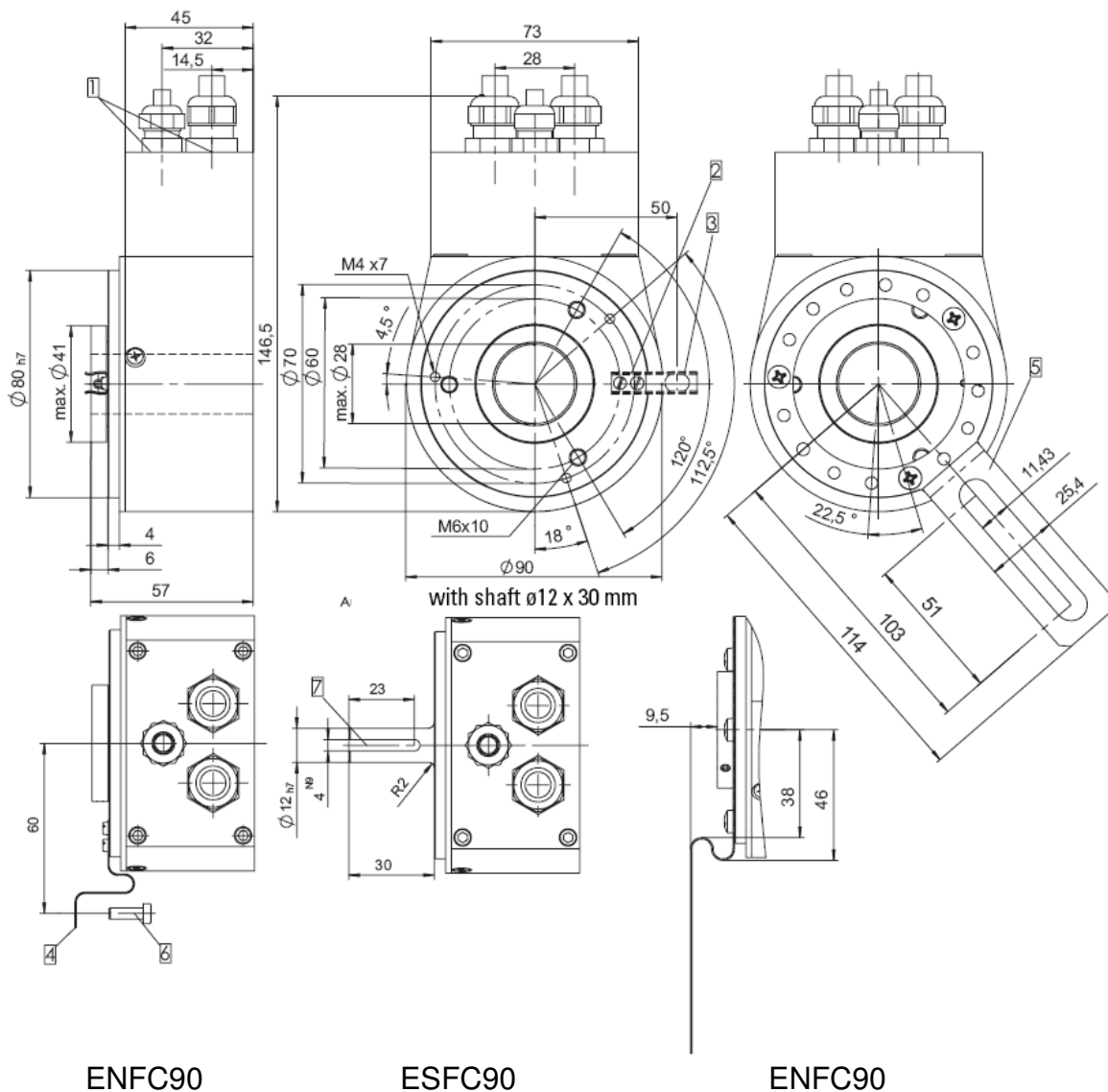

ENFC90

ESFC90

ENFC90

- 1 Socket box
- 2 Spring device short (Bracket No. 2) for pin acc. to DIN 6325 ø 6
- 3 Spring device long (Bracket No. 3) for pin acc. to DIN 6325 ø 6
- 4 Slotted hole for screw M4
- 5 Mounting bracket (Bracket No. 4)
- 6 2,5 mm deep

Mounting advice:

The brackets and shafts of the encoder and drive should not both be rigidly coupled together at the same time!

Absolute Multiturn Encoder with CANopen/DeviceNet-interface Absolute Multiturn Drehgeber mit CANopen/DeviceNet-Anschluss

Multiturn ENFC 90 CANopen/DeviceNet

Bus in:

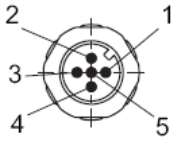

Signal :	DRAIN	+ V DC	- V DC	CAN_H	CAN_L
Pin:	1	2	3	4	5
	GY	RD	BK	WH	BU

Bus out:



Signal :	DRAIN	+ V DC	- V DC	CAN_H	CAN_L
Pin:	1	2	3	4	5
	GY	RD	BK	WH	BU

Use Couplings for the connection BUS-IN and Connectors for the connection BUS-OUT.
Compatible self-assembly connectors:

Connector (BUS-OUT): 05.B8251-0/9
Coupling (BUS-IN): 05.B8151-0/9
See also Connection Technology section for cable assemblies.

Dimension (M12 connector version):

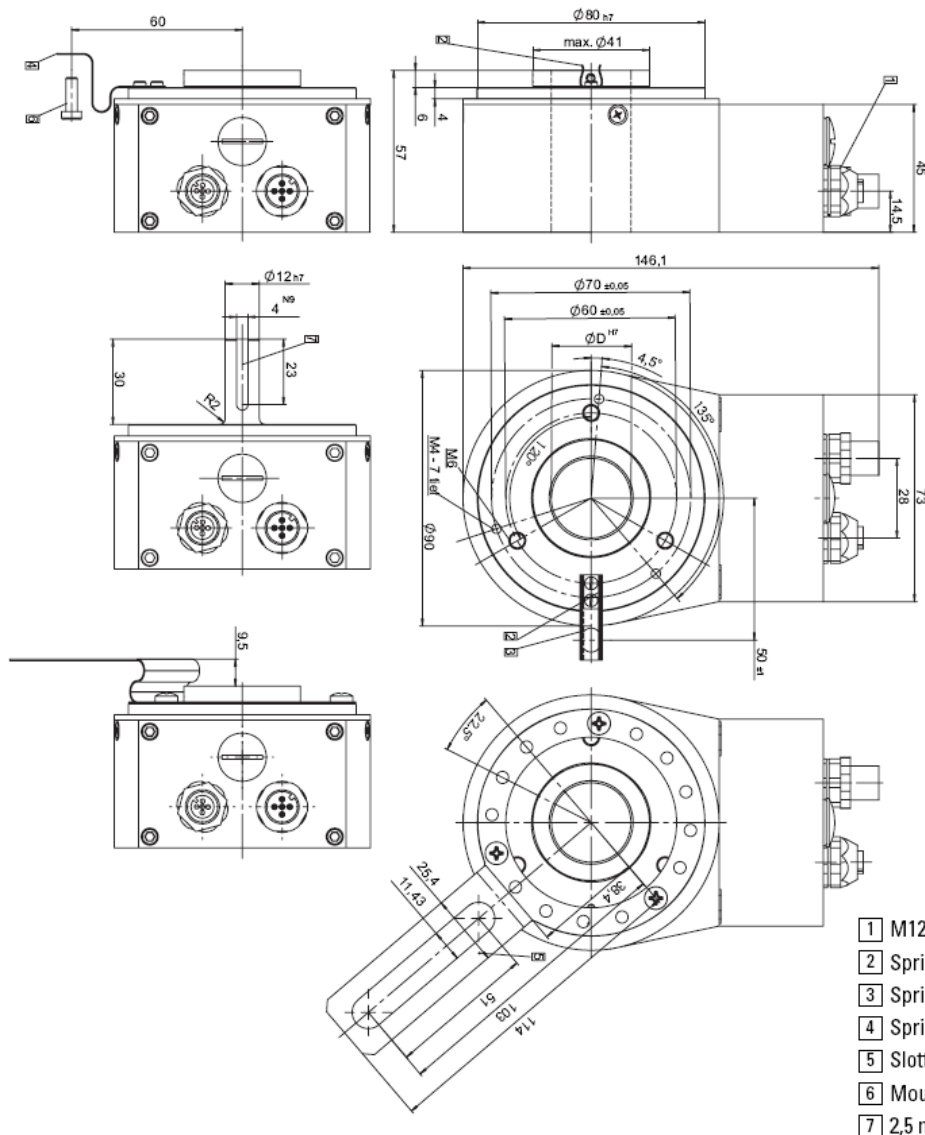

ENFC90

ESFC90

ENFC90

- 1 M12 Connectors/Coupling
- 2 Spring device for pin acc. to DIN 6325 06
- 3 Spring device short (Bracket No. 2)
- 4 Spring device long (Bracket No. 3)
- 5 Slotted hole for screw M4
- 6 Mounting bracket (Bracket No. 4)
- 7 2,5 mm deep

Multiturn ENFC 90 CANopen/DeviceNet

Patented "Integrated Technology®" uses single board construction, deliberate assembly techniques, and two ASIC design:

- Shock up to 250gs
- Higher vibration specs and thermal shock performance
- Lower parts count, elimination of potentiometers
- Higher resistance to EMI

Electronic multiturn increases performance, eliminates gears

- Reliability - No backlash errors, resistant to EMI, lower parts count
- Higher life - No mechanical wear, lower internal temperature
- Higher performance - Higher operating speeds
- Lower profile - compact size, hollow shaft
- Economical - Lower cost

Patented "Intelligent Sensing Technology®"

- The battery outlasts both application requirements and system components (LEDs & bearings)
- Redundant multiturn sensors and counters increase reliability & life
- Active system output monitoring using digital filters to compare data to logical & target bits.

Order code:

ENFC90.XX.XX.X001

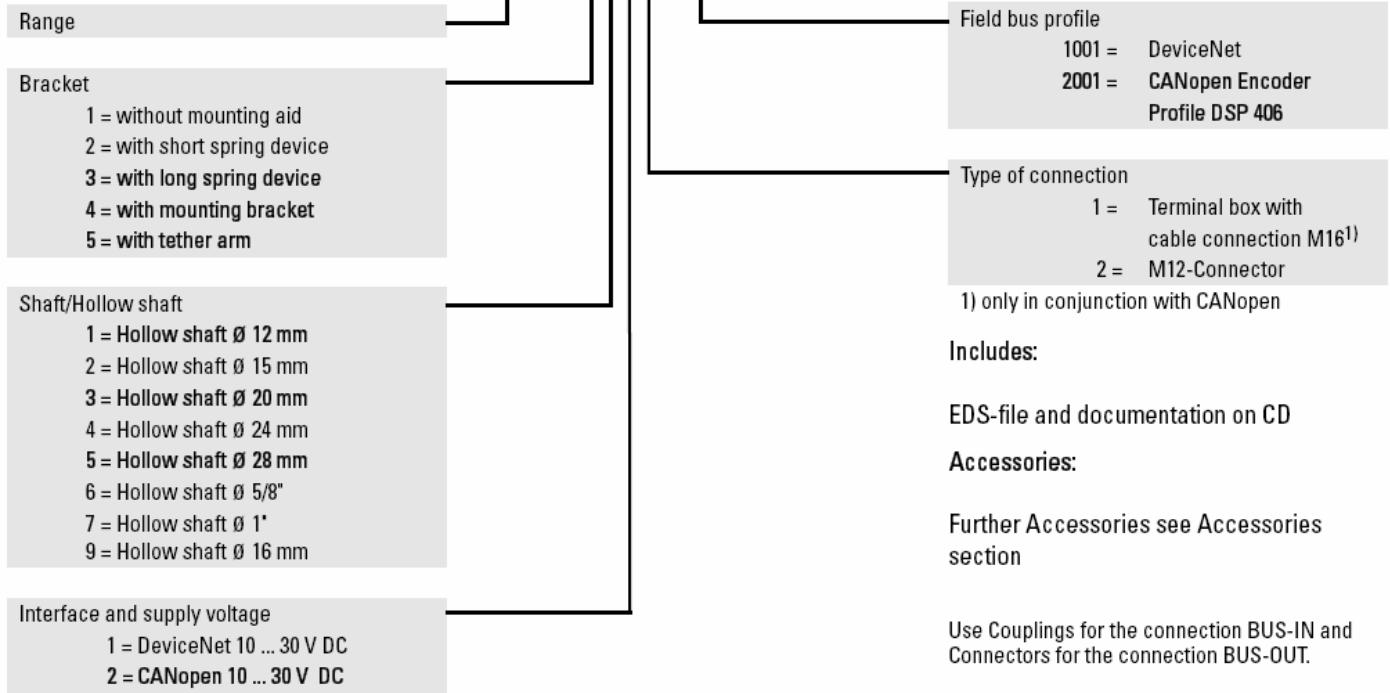

Includes:

EDS-file and documentation on CD

Accessories:

Further Accessories see Accessories section

Use Couplings for the connection BUS-IN and Connectors for the connection BUS-OUT.

Compatible self-assembly connectors:
 Connector (BUS-OUT): 9600.06.038