

Large Diameter Heavy duty ENI 100H

- Rugged: balanced, stainless-steel clamping rings, special bearing-shaft connection increases stability and vibration resistance
- Economic alternative to traditional heavy duty encoders that are often over-engineered and expensive
- Versatile due to compact size. Optional isolating inserts eliminate possible damage from shaft currents, for example with AC vector motors

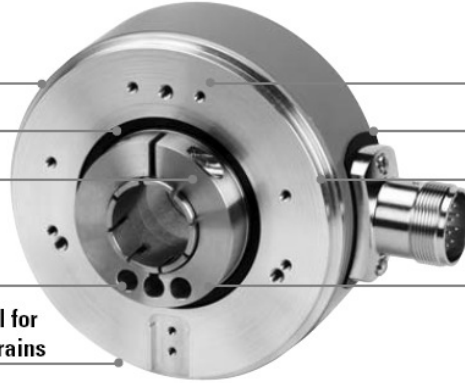

Only 49 mm clearance needed

Hollow shaft diameter up to Ø 42 mm

Very easy mounting without couplings

Optional:
Plastic isolating inserts
protect against shaft currents

New type of mechanical construction, ideal for handling tough mechanical stresses and strains

High scanning rate

RS 422, push-pull or SIN/COS outputs

Extended speed range up to 6000 min⁻¹

High-grade hub/shaft fixing,
balanced, stainless-steel
– ensures quiet vibration-free running



Mechanical characteristics:

Speed:	max. 6000 min ⁻¹ at 70°C ¹⁾ max. 3500 min ⁻¹ at 80°C ¹⁾
Rotor moment of inertia:	<220 x 10 ⁻⁶ kgm ² 2)
Starting torque with sealing:	< 0.2 Nm
Weight:	app. . 0.8 kg
Protection acc. to EN 60 529:	IP 65
Working temperature:	-20° C ... +80 °C ³⁾
Operating temperature:	-20° C ... +85 °C ³⁾
Shaft:	stainless-steel H7
Shock resistance acc. to DIN-IEC 68-2-27:	2000 m/s ² , 6 ms
Vibration resistance acc. to DIN-IEC 68-2-6:	100 m/s ² , 10...2000 Hz

Pulse rates available at short notice:

50*, 360*, 512, 600, 1000, 1024, 1500, 2000,
2048, 2500, 4096, 5000

*not with sine wave output

Other pulse rates on request

Ex available as explosion proof
zone 2 and 22

¹⁾ During the run-in-phase of approx. 2 seconds, reduce the limits for working temperature_{max} or speed_{max} by 1/3

²⁾ Dependent on the shaft diameter

³⁾ Non-condensing

Electrical characteristics RS 422 or push-pull output:

Output circuit:	RS 422 (TTL-compatible)	Push-pull	Push-pull (7272) ³⁾
Supply voltage:	5 V (±5 %) or 10 ... 30 V DC	10 ... 30 V DC	5 ... 30V DC
Power consumption (no load) without inverted signal:	not available	typ. 55 mA / max. 125 mA	–
Power consumption (no load) with inverted signal:	typ. 40 mA / max. 90 mA	typ. 80 mA/ max.150 mA	typ. 50 mA/ max.100 mA
Permissible load/channel:	max. ±20 mA	max. ±30 mA	max. ±20 mA
Pulse frequency:	max. 300 kHz	max. 300 kHz	max. 300 kHz
Signal level high:	min. 2.5 V	min. U _B -3 V	min. U _B -2.0 V
Signal level low:	max. 0.5 V	max. 2.5 V	max. 0.5 V
Rise time t _r	max. 200 ns	max. 1 µs	max. 1 µs
Fall time t _f	max. 200 ns	max. 1 µs	max. 1 µs
Short circuit proof outputs ¹⁾ :	yes ²⁾	yes	yes
Reverse connection protection at U _B :	5 V: no, 10 ... 30 V: yes	yes	no
Conforms to CE requirements acc. to EN 61000-6-1, EN 61000-6-4 and EN 61000-6-3			

¹⁾ If supply voltage correctly applied

²⁾ Only one channel allowed to be shorted-out
(If U_B=5 V, short-circuit to channel, 0 V, or +U_B is permitted)
(If U_B=5-30 V, short-circuit to channel or 0 V is permitted)

³⁾ Max. recommended cable length 30 m

Large Diameter Heavy duty ENI 100H

Electrical characteristics sine wave output:

Output circuit:	Sine U = 1 V _{SS}	Sine U = 1 V _{SS}
Supply voltage:	5 V (±5 %)	10 ... 30 V DC
Current consumption (no load) with inverted signals:	typ. 65 mA / max. 110 mA	typ. 65 mA / max. 110 mA
-3 dB frequency:	≥180 kHz	≥180 kHz
Signal level channels A/B:	1 V _{SS} (±20%)	1 V _{SS} (±20 %)
Signal level channel 0:	0.1 ... 1.2 V	0.1 ... 1.2 V
Short circuit proof outputs ¹⁾ :	yes	yes
Reverse connection protection at U _B :	no	yes
Conforms to CE requirements acc. to EN 61000-6-1, EN 61000-6-4 and EN 61000-6-3		

Mounting:

Mounting using the spring element - short

When mounting the encoder, ensure that dim. L is larger than the maximum axial play of the drive in the direction of the arrow.

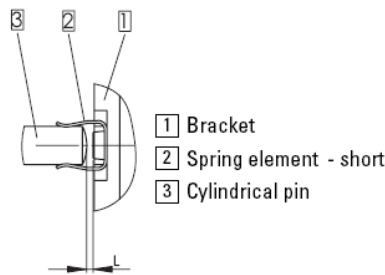

Mounting using the spring element – long
 Cylindrical pin fed through the bore of the spring

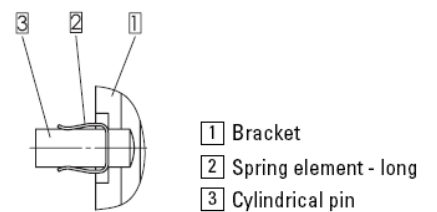

Terminal assignment:

Sig.:	0 V	0 V Sens ²⁾	+U _B	+U _B Sens ²⁾	A	\bar{A}	B	\bar{B}	0	$\bar{0}$	\perp
Pin:	10	11	12	2	5	6	8	1	3	4	PH ¹⁾
Col.:	WH	GY PK	BN	RD BU	GN	YE	GY	PK	BU	RD	

¹⁾ PH = Shield is attached to connector housing

²⁾ Sensor cables are connected to the supply voltage internally if long feeder cables are involved they can be used to adjust or control the voltage at the encoder. If the sensor cables are not in use, they have to be insulated or 0 V_{SENSOR} has to be connected to 0 V and U_{BSENSOR} has to be connected to U_B.

Using RS 422 outputs and long cable distances, a wave impedance has to be applied at each cable end. Insulate unused outputs before initial startup.

Incremental hollow shaft encoder Inkrementale Drehgeber in Hohlwellenausführung

Large Diameter Heavy duty ENI 100H

Dimensions:

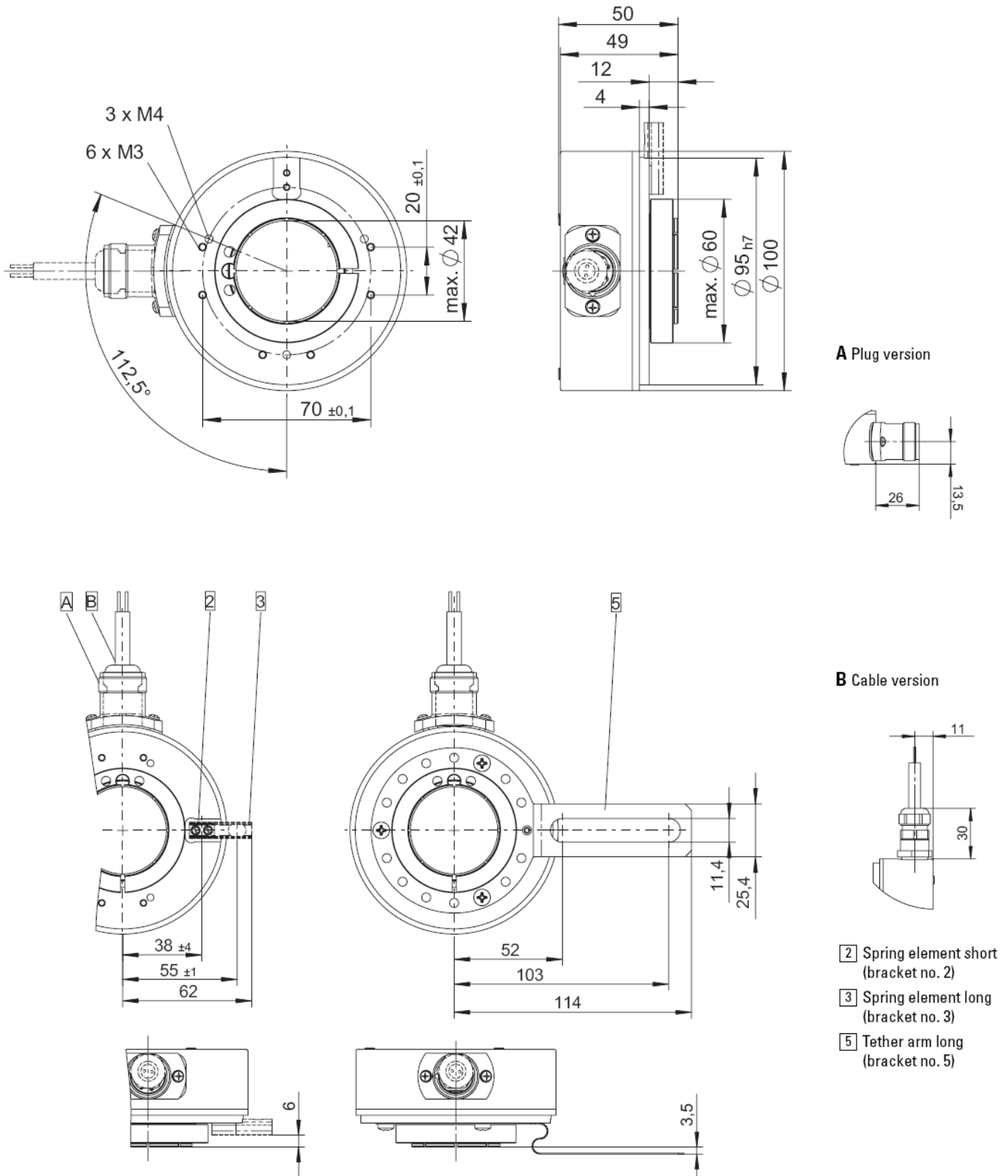

Note: minimum insertion depth $1.5 \times D_{\text{hollow shaft}}$

Large Diameter Heavy duty ENI 100H

Order code:

ENI 100HXXXX.XXXX

Range
ENI 100H = Heavy Duty execution

Pulse rate
(e.g. 360 pulses=> 0360)

Bracket
1 = without mounting aid
2 = with short spring device
3 = with long spring device
4 = with mounting bracket short¹⁾
5 = with mounting bracket long

Type of connection
1 = Cable radial (1 m PVC-cable)
2 = radial 12 pin plug without mating connector

Hollow shaft
1 = ø 42 mm
2 = ø 38 mm
3 = ø 28 mm
4 = ø 25.4 mm (1")
5 = ø 25 mm
6 = ø 24 mm
A = ø 30 mm
B = ø 40 mm
C = ø 20 mm
H = ø 35 mm
M = ø 19 mm

Output circuit and voltage display
1 = **RS 422 (with inverted signal)**
5 V supply voltage
2 = Push-pull (without inverted signal)
10 ... 30 V supply voltage
3 = **Push-pull (with inverted signal)**
10 ... 30 V supply voltage
4 = RS 422 (with inverted signal)
10 ... 30 V supply voltage
5 = Push pull (with inverted signal)
5 ... 30 V supply voltage
A = Line driver 7272
5 ... 30 V supply voltage

Preferred types are indicated in bold

Optional (on request):
– special connector pin out
– special output signals formats