

Hohlwellenversion ENI 37



- Economical version
- Compact unit size only $\varnothing 37 \times 32$ mm
- Very easy mounting. The encoder is mounted directly on the drive shaft without couplings. This saves up to 30 % cost and 60 % clearance compared to shaft versions.
- Temperature and ageing compensation
- Short circuit proof outputs
- Resolution up to 1024 ppr
- Protection up to IP 67
- available as explosion proof zone 2 and 22

- Bracket and cover made from a new High-Tech-Material (composite material)
- High component integration leads to low profile design, high performance and economical pricing
- "Tube Tech[®]" cable outlet guarantees 10x higher strain relief than traditional cabling methods plus higher IP-Protection.
- 1 1/2" (37 mm) diameter housing suitable for replacing resolvers

Mechanical characteristics:

Speed:	max. 6000 min ⁻¹
Rotors moment of inertia:	approx. 1.4×10^{-6} kgm ²
Starting torque:	< 0.01 Nm
Weight:	approx. 0.1 kg
Protection acc. to EN 60 529:	bearing, shaft: IP 65 cable outlet: IP 67
Working temperature:	-20° C up to +70 °C ¹⁾³⁾
Operating temperature:	-20° C up to +80 °C ²⁾³⁾
Materials:	shaft: stainless steel; housing, bracket: composite PPA, 40 % KF (carbon fibre) cable: PVC
Shock resistance acc. to DIN-IEC 68-2-27:	1000 m/s ² , 6 ms
Vibration resistance acc. to DIN-IEC 68-2-6:	100 m/s ² , 10 ... 2000 Hz

Pulse rates available at short notice:

10, 50, 100, 180, 200, 250, 300, 360, 400, 500, 512, 600, 1000, 1024

Other pulse rates available on request

¹⁾ At push pull output and Supply voltage > 15 V DC: max. 55 °C
²⁾ At push pull output and Supply voltage > 15 V DC: max. 60 °C

³⁾ Non-condensing

Electrical characteristics:

Output circuit:	RS 422 (TTL-compatible)	Push-pull (7272) ³⁾	Push-pull (7272) ³⁾
Supply voltage:	5 V ($\pm 5\%$)	5 ... 30 V DC	10 ... 30 V DC
Power consumption (no load) with inverted signal:	typ. 40 mA / max. 90 mA	typ. 50 mA/ max. 100 mA	typ. 50 mA/ max. 100 mA
Permissible load/channel:	max. ± 20 mA	max. ± 20 mA	max. ± 20 mA
Pulse frequency:	max. 250 kHz	max. 250 kHz	max. 250 kHz
Signal level high:	min. 2.5 V	min. $U_B - 2.5$ V	min. $U_B - 2.5$ V
Signal level low:	max. 0.5 V	max. 0.5 V	max. 0.5 V
Rise time t_r	max. 200 ns	max. 1 μ s	max. 1 μ s
Fall time t_f	max. 200 ns	max. 1 μ s	max. 1 μ s
Short circuit proof outputs ¹⁾ :	yes ²⁾	yes	yes
Reverse connection protection at U_B :	no	no	yes
Conforms to CE requirements acc. to EN 61000-6-1, EN 61000-6-4 and EN 61000-6-3			

¹⁾ If supply voltage correctly applied
²⁾ Only one channel allowed to be shorted-out:
(at $U_B = 5$ V short circuit to channel, 0 V, or $+U_B$ is permitted)

³⁾ Max. recommended cable length 30 m

Applications:

- Substitute for resolvers
- Packaging machines
- Electrical machines
- Vehicles
- Conveyers, elevators
- Semiconductor machines
e.g. pick & place, cutting ...
- Material handling
- Special machines

technische Änderungen vorbehalten / Subject to change without prior notice

Hohlwellenversion ENI 37

Terminal assignment

Signal:	0 V	+U _B	A	\bar{A}	B	\bar{B}	0	$\bar{0}$	Shield
Colour:	WH	BN	GN	YE	GY	PK	BU	RD	

Using RS 422 outputs and long cable distances, a wave impedance has to be applied at each cable end.

Insulate unused outputs before initial startup.

Dimension

Short torque stop version;
Long torque stop version is dashed

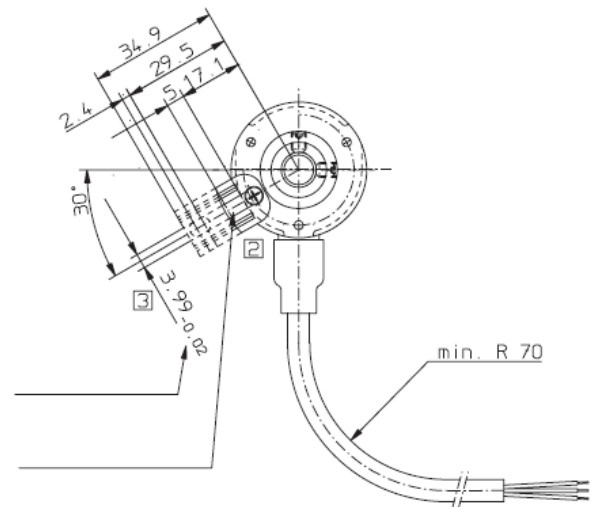
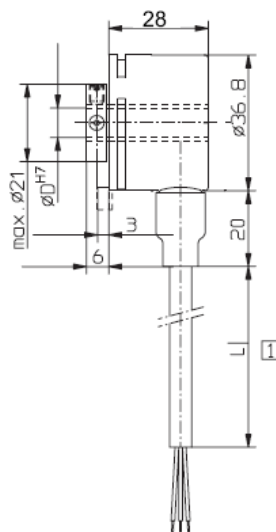

Stator coupling version

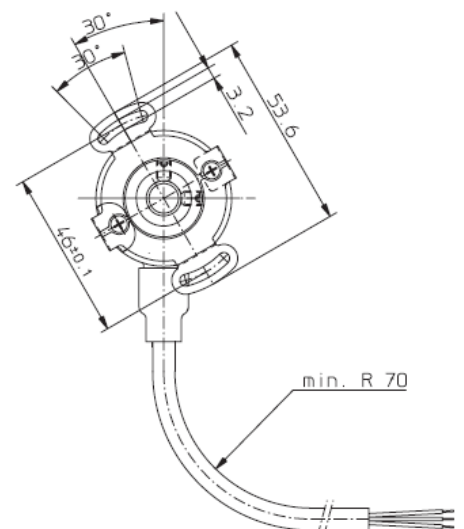
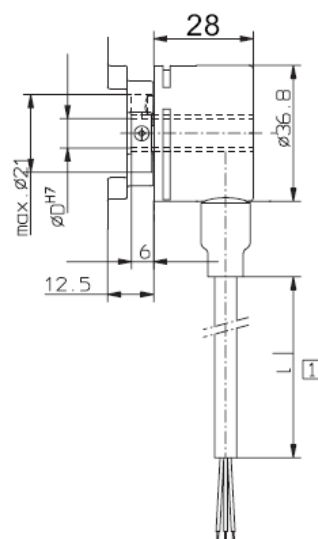

- 1 cable length 1, 2, 3 or 5 m
- 2 Slot for support torque, 3 mm deep
- 3 Recommended pin for long torque stop
Cyl. pin acc. to DIN 7 \varnothing 4 mm

Hohlwellenversion ENI 37

Mounting advice:

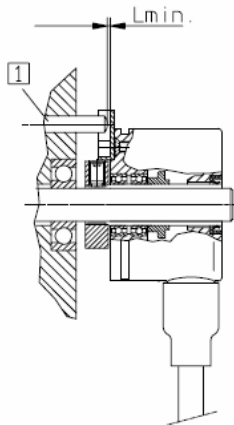

1 Cyl.-pin to DIN 7 \varnothing 4 mm

Mounting advice:

- 1) The brackets and shafts of the encoder and drive should not both be rigidly coupled together at the same time.
- 2) When mounting a hollow shaft encoder, we recommend using a torque stop pin or a stator coupling.
- 3) When mounting the encoder ensure the dimension Lmin. is larger than the maximum axial play of the drive.

Order code:

ENI37.XXXX.XXXX

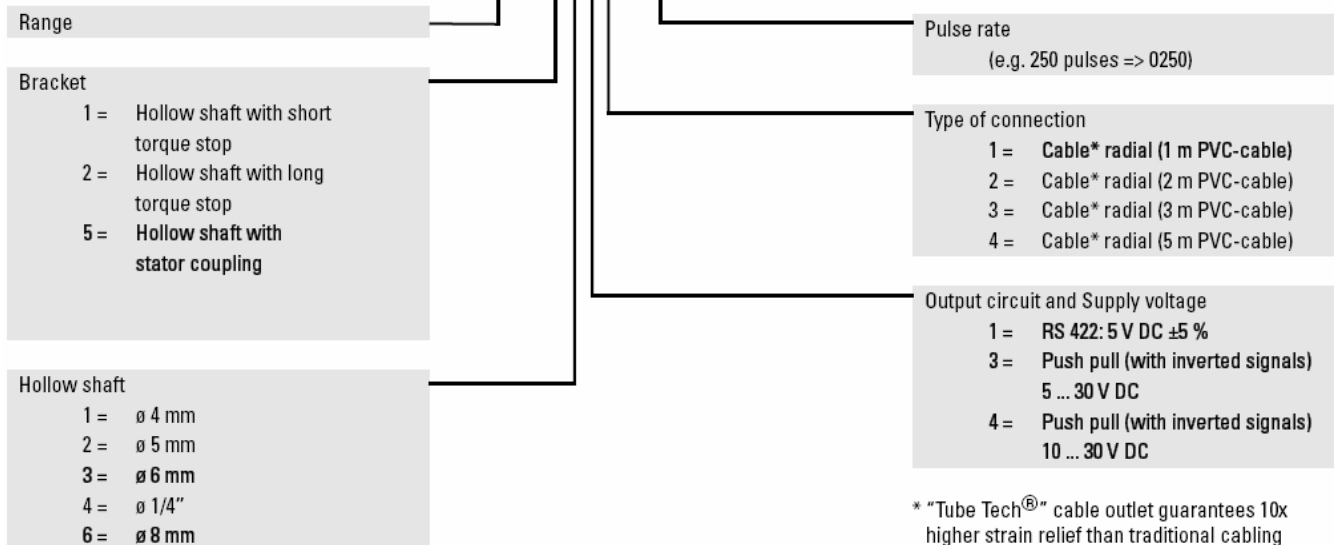

* "Tube Tech[®]" cable outlet guarantees 10x higher strain relief than traditional cabling methods plus higher IP-Protection.

Other cable lengths are available on request.