

Serie ESM 60



- **Impulse / Pulses** 100
(Feinrastrung / Precision click point)
- **Kanäle / Channels** A / B
- **Speisespannung / Power supply** 5V oder/or 12V DC
- **Ausgangstreiber / Output driver** Pull up
- **Schutzart (montiert) / Protection (mounted)** IP 50

Ausgangssignal / Output channels Ausgangstreiber / Output driver Anschlüsse / Connection

cp = Rasterabstand / Click point
p = Periode

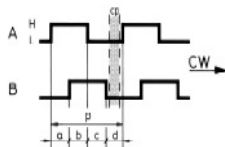

Pull up (NPN) 2 K Ω
Pull up (NPN) 330 Ω (FANUC)

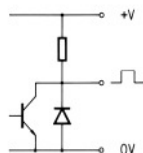

Schraubklemme / Terminal block

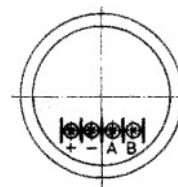

Massbild / Outline drawing

Bohrplan / Cut out

³⁾ Auf Anfrage / On request

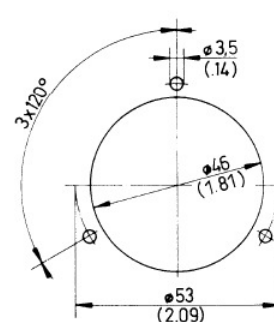
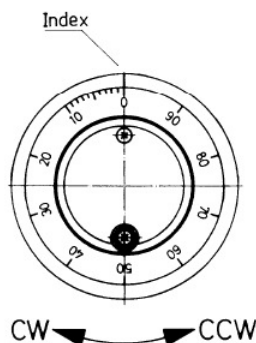
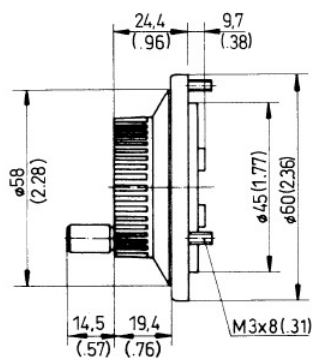

Serie ESM 60

Bestellschlüssel/ Order key

ESM60 1 1 1 1 1

Number of channels:

1 = A / B

Pulses / Revolution:

1 = 100

Power supply:

1 = 4,5... 13,2V DC

Output driver:

1 = Pull-up

Connection (Terminal block):

1 = at rear side