

Type MR 190



- Impulse / Pulses 100
- Kanäle / Channels A + B
- Speisespannung / Power supply 5V oder/or 12V DC
- Ausgangstreiber / Output driver Pull up / Line driver
- Schutzart / Protection IP50

Technische Daten / Technical data

Stromverbrauch	Current consumption	max. 70mA
Abtastfrequenz	Scanning frequency	max. >5 kHz
Ausgangsspannung RS 422	Output current RS 422	Zw. 0 und/and +4.8V immer vorhanden / always available
Ausgang A und B umschaltbar	Output A and B switchable	Zw. 0 und/and +5V oder/or zw. 0 und/and VCC
Signalpegel	Output voltage	Vcc -0.7V
Auflösung	Resolution	1% = 3.6°
Drehmoment	Torque	<0.2Ncm
Rastmoment (Click point)	Torque (click point)	8Ncm
Lebensdauer	Rotation life (Notched disc)	1.10 ⁶ Umdr. (200 rpm)
Arbeits- / Lagertemperatur	Operating- / Storage temperature	-10°C +60°C / -20°C +70°C
Luftfeuchtigkeit	Atmospheric humidity	85% RH
Vibration / Schock	Vibration / Shock	10...55 Hz 1.5mm 2hr / 50G (11ms) X, Y, Z
Gewicht	Weight	200g

Ausgangskanäle / Output channels

cp = Rasterabstand / Click point

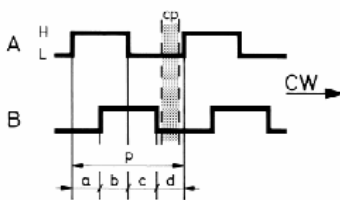

Line driver (RS 422 A)

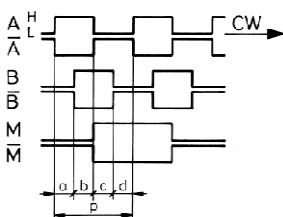

Ausgangstreiber / Output driver

Pull up (2 K0 intern)

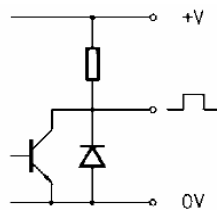

Line driver (RS 422 A)

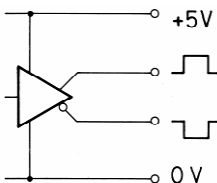

Anschlüsse / Connection

Schraubklemme / Terminal block

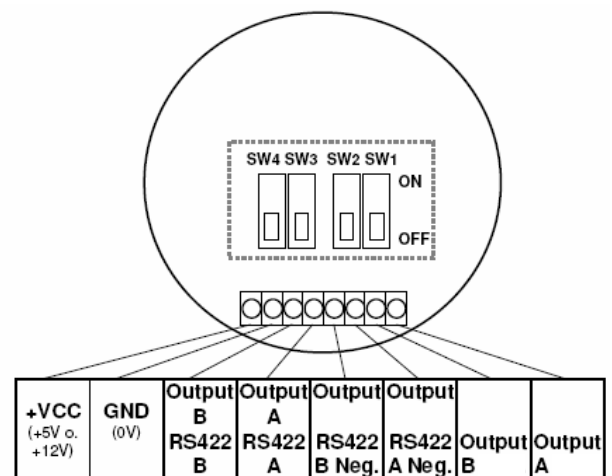

Every MR 190 unit is supplied with Phoenix Combicon Compact series Screw-Clamp Terminal Block Plug (www.phoenixcontact.com)
Phoenix order No. 1984076
Model No. PT 1.5/8-PVH-3.5

Type MR 190

Schaltereinstellungen / Switch configuration

No.(X)	Schalter SW1.....SW4				VCC	RC	Ausgang Spannung Max		
	SW1	SW2	SW3	SW4			A	B	
1	OFF	OFF	OFF	OFF	4.9->5.3V	326 Ohm	4V	4V	P + L
2	OFF	OFF	OFF	OFF	11.9->12.5V	326 Ohm	4V	4V	P
3	OFF	ON	OFF	ON	4.9->5.3V	2 KOhm	4V	4V	P + L
4	OFF	ON	OFF	ON	11.9->12.5V	2 KOhm	4V	4V	P
5	ON	OFF	ON	OFF	4.9->5.3V	390 Ohm	4V	4V	P + L
6	ON	OFF	ON	OFF	11.9->12.5V	390 Ohm	4V	4V	P
7	ON	ON	ON	ON	4.9->5.3V	2 KOhm	4V	4V	P + L
8	ON	ON	ON	ON	11.9->12.5V	2 KOhm	11V	11V	P

P = Pull up;

L = Line driver

Einstellungen am MR190 für die abgelösten Handeingabegeräte / Configuration for old types of Handy-Pulser

Alte Typ / Old Type	Schalter Einstellung/ Switch Configuration
ESM70	3 (MR190.3)
ESM72	8 (MR190.8)
ESM74	7 (MR190.7)
ESM80 FANUC	1 (MR190.1)

Massbild (Zoll in Klammern) / Outline drawing (inch in brackets)

Bohrplan / Cut out

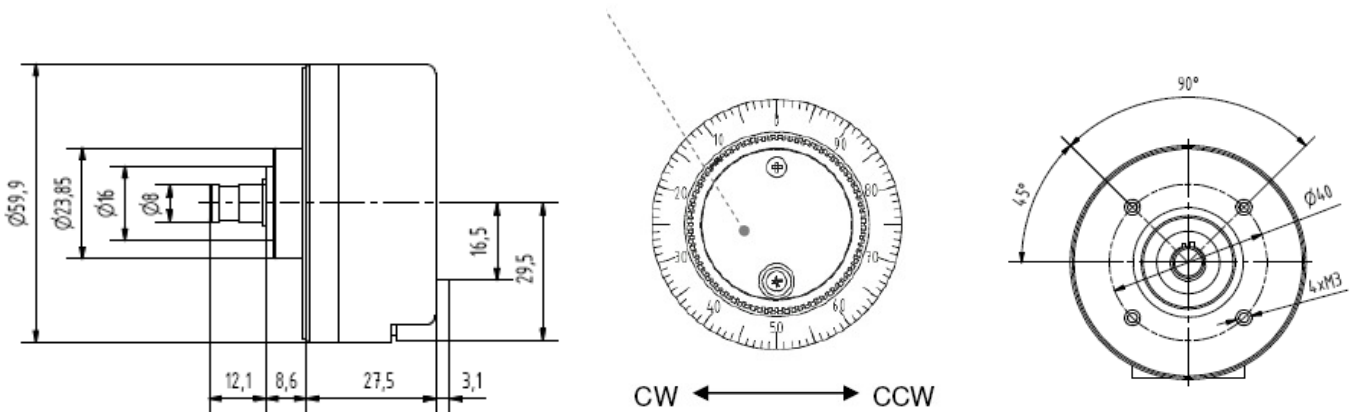

Bestellschlüssel / Order key

