

POSIROT®
PRAS3
Magnetic Angle Sensor with Analog Output

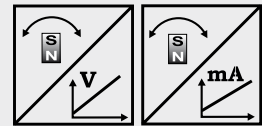

Magnetic angle sensor 0 - 360 degrees in a 36 mm dia. housing

- With 10 mm shaft or 6 mm hollow shaft
- Protection class IP67/IP69K
- Magnetic measurement principle
- Outputs:
 Voltage 0.5 ... 4.5 V, 0.5 ... 10 V
 Current 4 ... 20 mA
- Redundant second channel as option



Specifications	Outputs	Voltage: 0.5 ... 4.5 V; 0.5 ... 10 V Current: 4 ... 20 mA, 3 wire
	Resolution	0.03 % (60 ... 360); 0.1 % (15 ... 45°)
	Repeatability	±0.03 % (60 ... 360°); ±0.1 % (15 ... 45°)
	Linearity	±0.3 % f.s. (typ.)
	Measurement range	0 ... 15° to 0 ... 360°, standard 360°
	Signal characteristics	CW, CCW
	Material	Stainless steel / aluminium / zinc (depends on the model)
	Mounting	Clamps, mounting plate
	Protection class	IP67 (IP67/IP69K option, housing)
	Shock	EN 60068-2-27:1993, 100 g/11 ms, 100 shocks
	Vibration	EN 60068-2-6:1995, 20 g 10 Hz-2 kHz, 10 cycles
Life cycle of bearings	100 x 10 ⁶ revolutions (<1500 r.p.m.)	
Revolutions per minute	Max. 10,000 r.p.m.	
Allowable shaft load	100 N radial, 100 N axial	

Order Code PRAS3

PRAS3 - [] - [] - [] - [] - []

Model name _____

Shaft

V = 10 mm shaft
 H = 6 mm hollow shaft

Measurement range 15 ... 360° in steps of 15°

15 / 30 / 45 / ... / 345 / 360

Output (see page 26)

U6 = 0.5 ... 4.5 V ratiometric
 U2 = 0.5 ... 10 V
 I1 = 4 ... 20 mA, 3 wire

Signal characteristics

CW = Signal increasing CW
 CCW = Signal increasing CCW

Connection

KAB2M = Cable, standard length 2 m, IP67
 KAB2M69K = Cable, standard length 2 m, IP67/IP69K
 M12A5 = 5-pin socket M12 axial (compatible with 4-pin connector)
 M12R5 = 5-pin socket M12 radial (compatible with 4-pin connector), (in preparation)

Order code mounting clamps (set of 3 pieces)

PRPT-BFS1

Order code connector cable (see accessories page 32)

KAB-2M-M12/4F/G-LITZE

Order example: PRAS3 - V - 360 - I1 - CW - KAB2M

POSIROT® PRAS3/PRDS3 Dimensions



Outline drawing
sensor with shaft

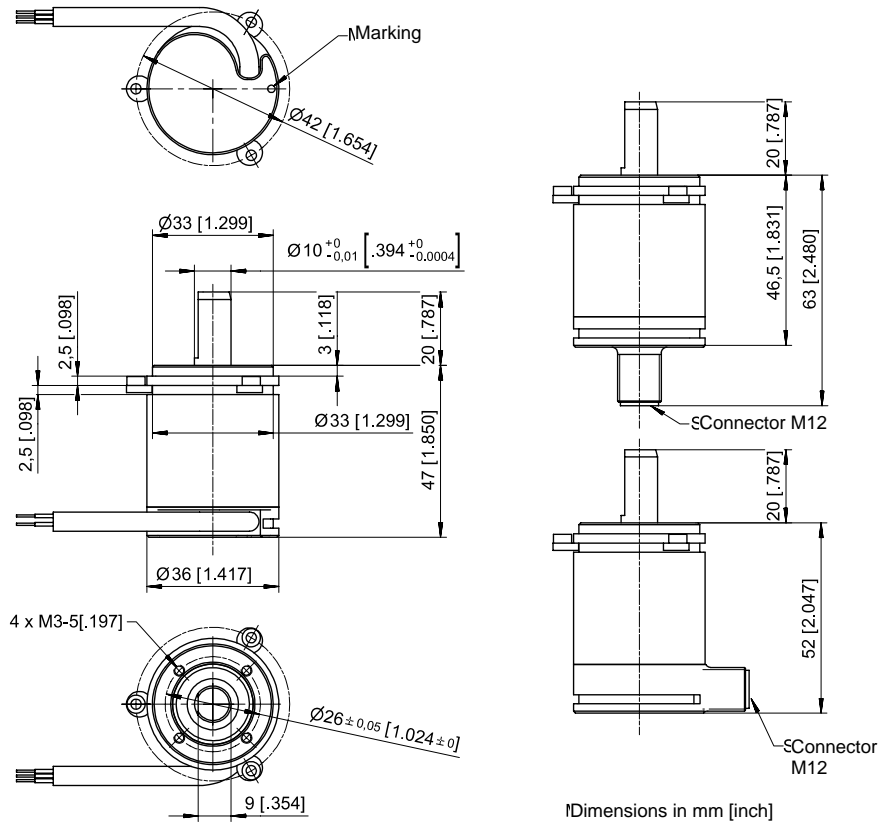

Outline drawing
sensor with hollow
shaft

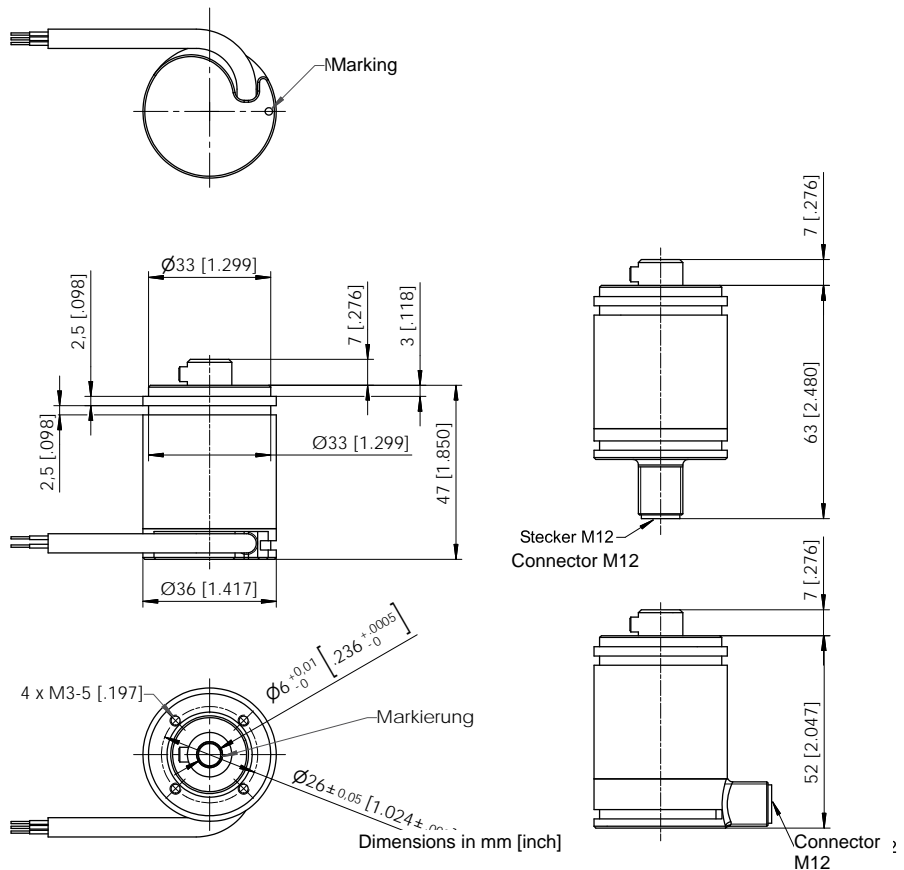

Weight without cable 250 g approx.
Dimensions informative only.
For guaranteed dimensions please consult factory.

POSIROT® – PRAS, POSITILT® – PTAS

Outputs U2(B), U6 and I1(B)



U2 / U2B Voltage Output 0.5 ... 10 V 	Excitation voltage	U2: 18 ... 36 V DC; U2B: 11.5 ... 27 V DC
	Excitation current	40 mA max.
	Output voltage	0.5 ... 10 V DC
	Output current	2 mA max.
	Measuring rate	1 kHz standard
	Stability (temperature)	±50 x 10 ⁻⁶ / °C f.s. (typ.) for 90°...360° ±100 x 10 ⁻⁶ / °C f.s. (typ.) for <90°
	Operating temperature	-40 ... +85 °C (+105 °C as option)
	Protection	Reverse polarity, short circuit
	EMC	According to EN 61326:2004

U6 = U6/5 / U6/8,25 Voltage Output 10 ... 90 % ratiometric 	Excitation voltage	5V DC ±10 % / 8.25 V DC ±10 %
	Excitation current	40 mA max.
	Output voltage	10 ... 90 % of the excitation voltage
	Output current	2 mA max.
	Measuring rate	1 kHz standard
	Stability (temperature)	±50 x 10 ⁻⁶ / °C f.s. (typ.) for 90°...360° ±100 x 10 ⁻⁶ / °C f.s. (typ.) for <90°
	Operating temperature	-40 ... +85 °C (+125 °C as option)
	Protection	Reverse polarity, short circuit
	EMC	According to EN 61326:2004

I1 / I1B Current Output 4 ... 20 mA 	Excitation voltage	I1: 18 ... 36 V DC; I1B: 10 ... 18 V DC
	Excitation current	60 mA max.
	Load resistor	I1: 500 Ω max.; I1B: 250 Ω max.
	Output current	4 ... 20 mA
	Measuring rate	1 kHz standard
	Stability (temperature)	±50 x 10 ⁻⁶ / °C f.s. (typ.) for 90°...360° ±100 x 10 ⁻⁶ / °C f.s. (typ.) for <90°
	Operating temperature	-40 ... +85 °C
	Protection	Reverse polarity, short circuit
	EMC	According to EN 61326:2004

Other outputs available on request.

Output signals

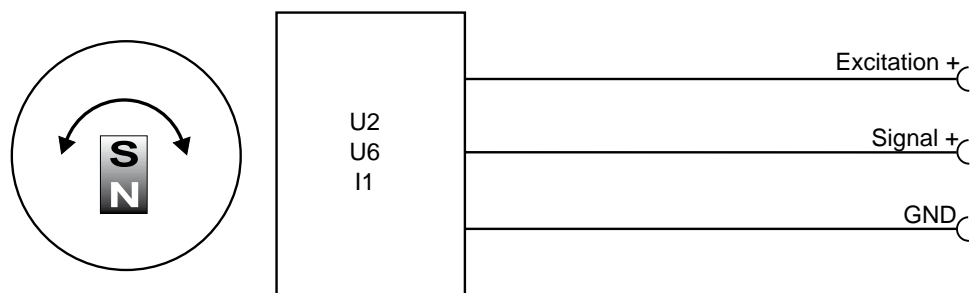

Signal Wiring	Output signals	Connector pin	Cable color
	Excitation +	1	brown
	Signal	2	white
	GND	3	blue
	Do not connect!	4	black
	Do not connect!	5	-

Connection

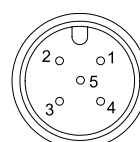

View to sensor connector

M12A5 / M12R5

POSIROT[®]

Characteristics for magnetic angle sensors



Output signal
(CW increasing)

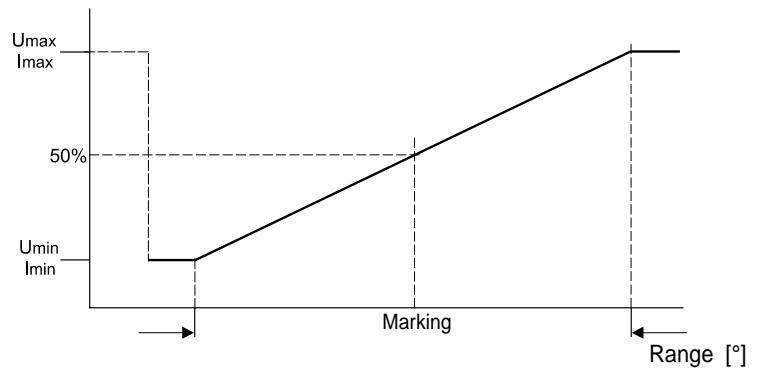

Output signal
(CCW increasing)

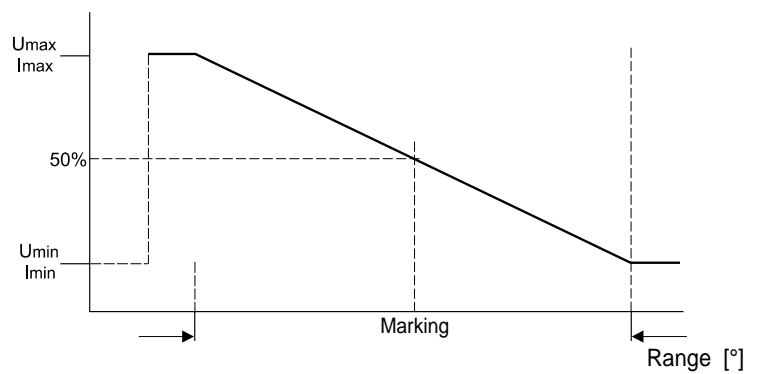

Example angular
range 90°

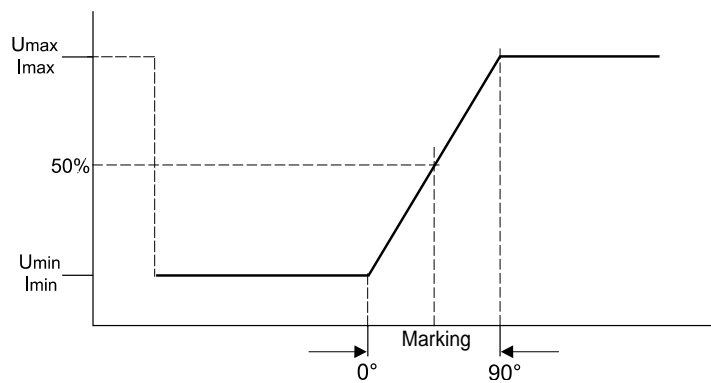

Example angular
range 360°

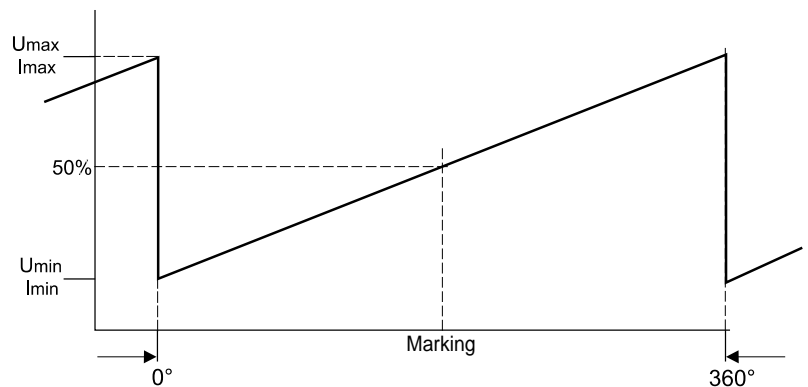

PRMAG1
PRMAG1-Z

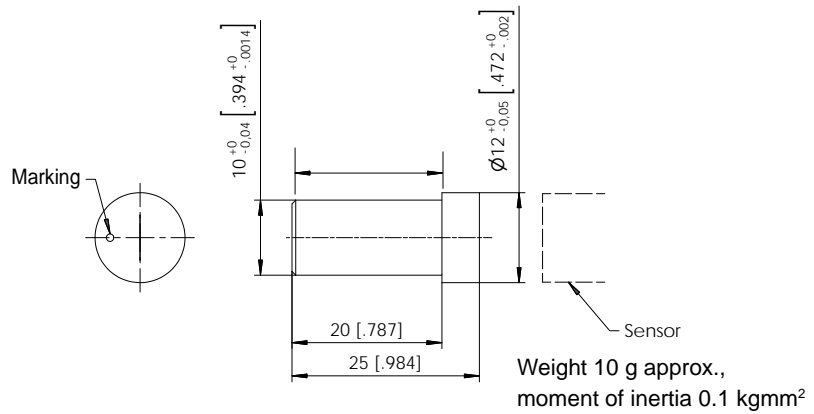

PRMAG2
PRMAG2-Z

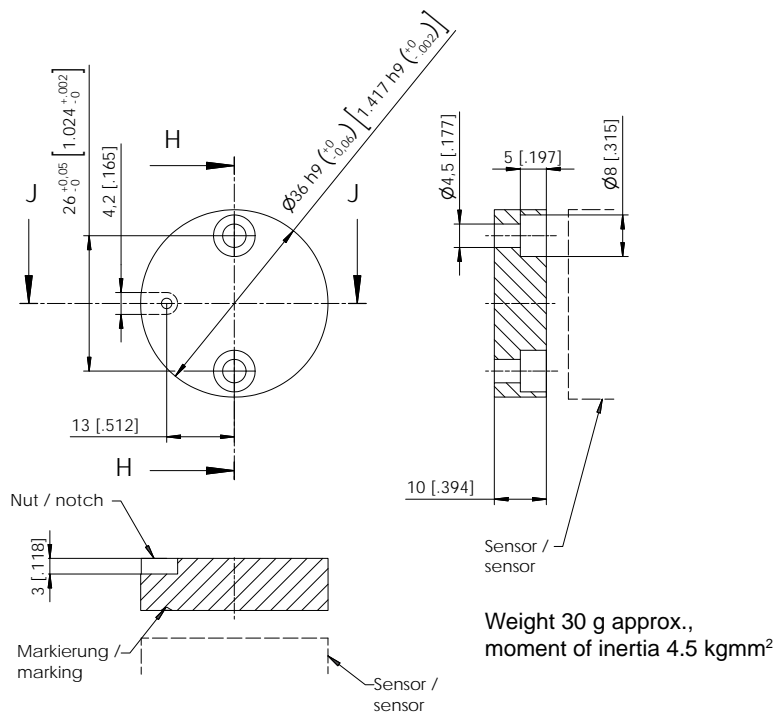

PRMAG20

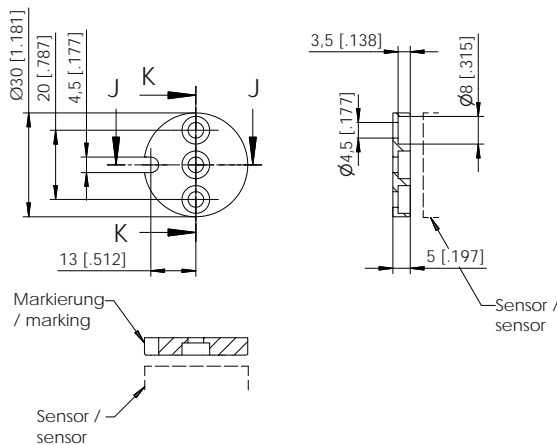

Dimensions in mm [inch]

Dimensions informative only
 For guaranteed dimensions please consult factory

POSIROT® Accessories Position magnets



Sensor	Position magnet	Air gap [mm]	Parallelism [°]	Error by axial misalignment [°]					
				0.2 mm	0.5 mm	1 mm	2 mm	3 mm	4 mm
PRAS1	PRMAG1	0 ... 3.5	5	0.1	0.3	2.0	13.5	–	–
	PRMAG1-Z	0 ... 4.5	5	0.1	0.3	1.5	6.5	–	–
	PRMAG20	0 ... 6.5	5	0.15	0.4	0.8	2.2	5.0	–
PRAS2	PRMAG2	0 ... 5	5	0.1	0.3	0.8	1.8	6.5	–
	PRMAG2-Z	0 ... 9	5	0.1	0.2	0.6	1.5	4.5	8.5
	PRMAG20	0 ... 6	5	0.15	0.4	0.8	2.2	5.0	–
PRAS5	PRMAG2	0 ... 4.5	5	0.1	0.3	0.8	1.8	6.5	–
	PRMAG5-Z	0 ... 7.5	5	0.1	0.2	0.6	1.5	4.5	8.5
	PRMAG20	0 ... 5.5	5	0.15	0.4	0.8	2.2	5.0	–
PRAS20	PRMAG2	0 ... 4.6	5	0.1	0.3	0.8	1.8	6.5	–
	PRMAG20	0 ... 3.5	5	0.15	0.4	0.8	2.2	5.0	–
PRAS21	PRMAG2	0 ... 3.6	5	0.1	0.3	0.8	1.8	6.5	–
	PRMAG20	0 ... 4.6	5	0.15	0.4	0.8	2.2	5.0	–

Sensor	Position magnet	Air gap [mm]	Parallelism [°]	Error by axial misalignment [°]					
				0.2 mm	0.5 mm	1 mm	2 mm	3 mm	4 mm
PRDS1	PRMAG1	0 ... 3	5	0.1	0.3	2.0	13.5	–	–
	PRMAG1-Z	0 ... 4	5	0.1	0.3	1.5	6.5	–	–
	PRMAG20	0 ... 4.5	5	0.15	0.4	0.8	2.2	5.0	–
PRDS2	PRMAG2	0 ... 5	5	0.1	0.3	0.8	1.8	6.5	–
	PRMAG2-Z	0 ... 7	5	0.1	0.2	0.6	1.5	4.5	8.5
	PRMAG20	0 ... 4	5	0.15	0.4	0.8	2.2	5.0	–
PRDS5	PRMAG2	0 ... 4.5	5	0.1	0.3	0.8	1.8	6.5	–
	PRMAG5-Z	0 ... 5.5	5	0.1	0.2	0.6	1.5	4.5	8.5
	PRMAG20	0 ... 3.5	5	0.15	0.4	0.8	2.2	5.0	–

Note: Sensor and position magnet must be mounted aligned!

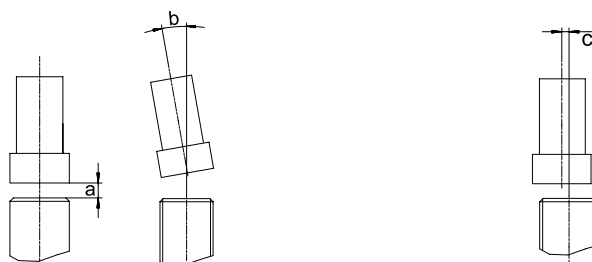

POSIROT® Accessories Mounting Plates



PRPT-BPL1

(screw mounting)
For PRAS2, PRDS2,
PRAS3, PRDS3

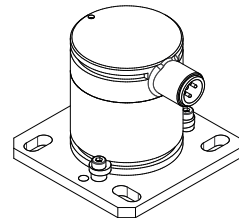
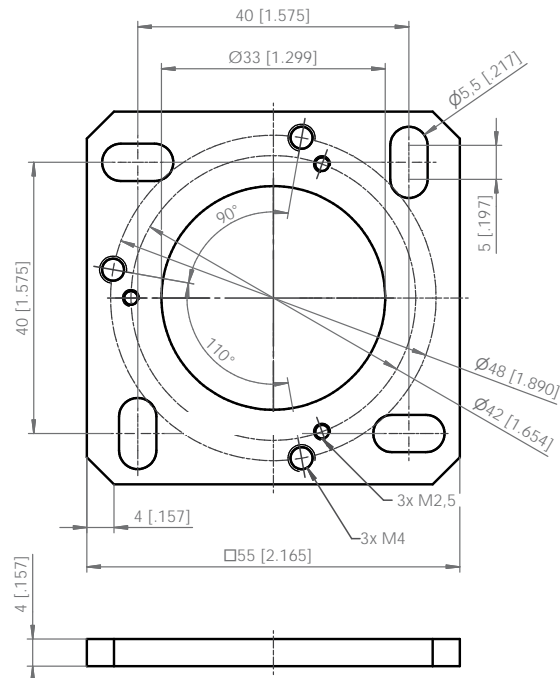

In combination with the
mounting clamps
PRPT-BFS1 (3 x M2.5).

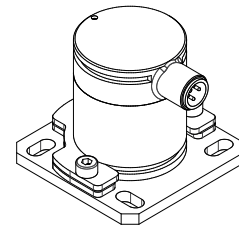

In combination with the
mounting brackets
PRPT-BFS2 (3 x M4).

Dimensions in mm [inch]

Weight 30 g approx.
Dimensions informative only.
For guaranteed dimensions please consult factory.

PRPT-BPL2

(welding assembly)
For PRAS2, PRDS2,
PRAS3, PRDS3

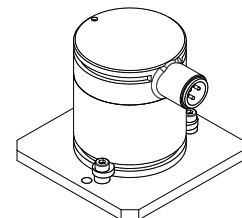
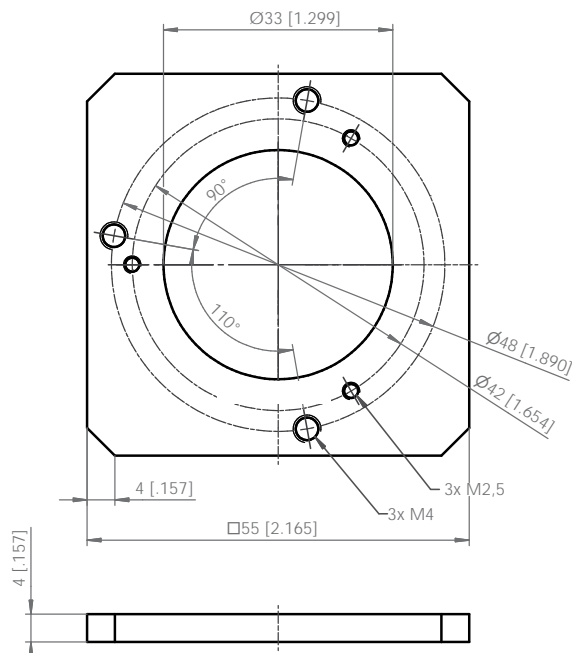

In combination with the
mounting clamps
PRPT-BFS1 (3 x M2.5).

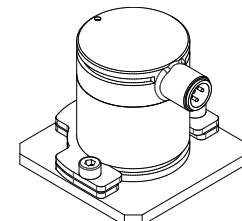

In combination with the
mounting brackets
PRPT-BFS2 (3 x M4).

POSIROT® Accessories Mounting Plates



PRPT-BPL3

For PRAS3, PRDS3

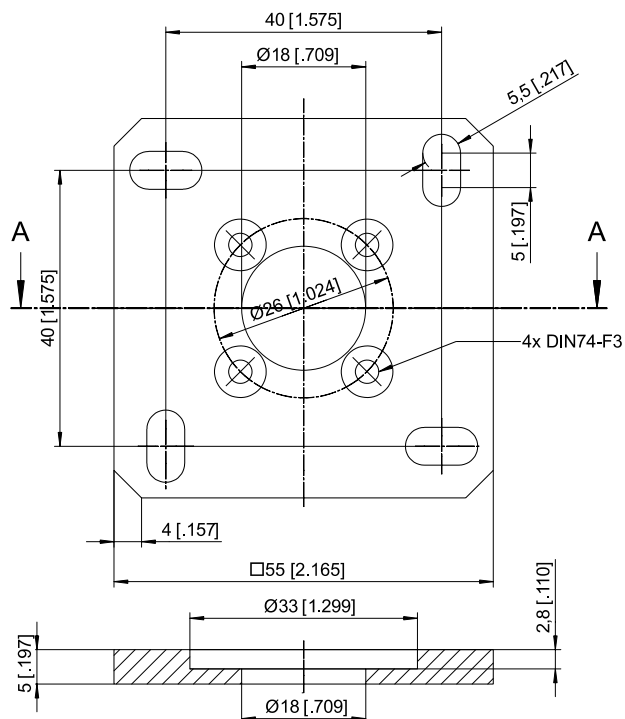

Dimensions in mm [inch]

Weight 30 g approx.

Dimensions informative only.

For guaranteed dimensions please consult factory.

POSIROT® Accessories Connector Cables



Connector cable for POSIROT® angle sensors 4 pins M12

Suitable for 5-pin sensor connectors M12A5 and M12R5

The 4-core screened cable is supplied with a mating 4-pin 90° M12 connector at one end and 4 wires at the other end. Available lengths are 2, 5 and 10 m.

Order code:

KAB - XM - M12/4F/W - LITZE

IP69K: **KAB - XM - M12/4F/W/69K - LITZE**

Length in m

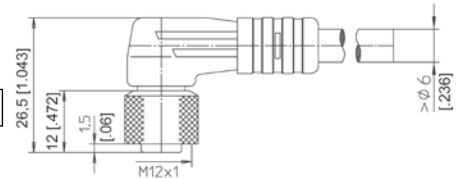
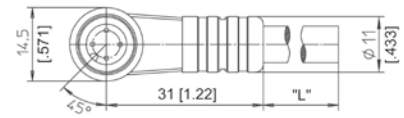

Connector cable for POSIROT® angle sensors 4 pins M12

Suitable for 5-pin sensor connectors M12A5 and M12R5

The 4-core screened cable is supplied with a mating 4-pin M12 connector at one end and 4 wires at the other end. Available lengths are 2, 5 and 10 m.

Order code:

KAB - XM - M12/4F/G - LITZE

IP69K: **KAB - XM - M12/4F/G/69K - LITZE**

Length in m

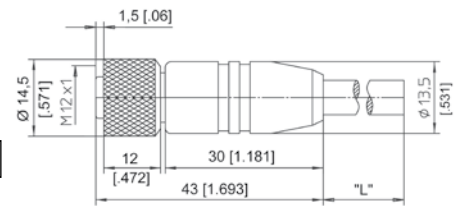

Signal wiring M12, 4 pin

Connector pin / cable color

1	2	3	4
Brown	White	Blue	Black

Connector cable for POSIROT® angle sensors 8 pins M12

The 8-core screened cable is supplied with a mating 8-pin 90° M12 connector at one end and 8 wires at the other end. Available lengths are 2, 5 and 10 m.

Order code:

KAB - XM - M12/8F/W - LITZE

IP69K: **KAB - XM - M12/8F/W/69K - LITZE**

Length in m

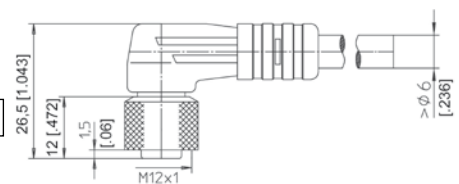
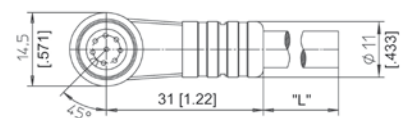

Connector cable for POSIROT® angle sensors 8 pins M12

The 8-core screened cable is supplied with a mating 8-pin M12 connector at one end and 8 wires at the other end. Available lengths are 2, 5 and 10 m.

Order code:

KAB - XM - M12/8F/G - LITZE

IP69K: **KAB - XM - M12/8F/G/69K - LITZE**

Length in m

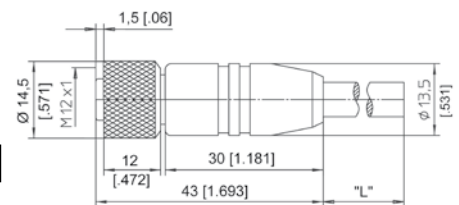

Signal wiring M12, 8 pin

Connector pin / cable color

1	2	3	4	5	6	7	8
White	Brown	Green	Yellow	Grey	Pink	Blue	Red